

FRACTION Tool Kit

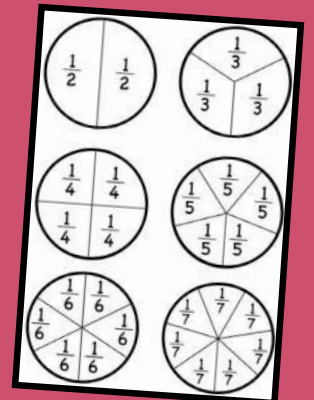

Fractions

1									
$\frac{1}{2}$	$\frac{1}{2}$								
$\frac{1}{3}$	$\frac{1}{3}$	$\frac{1}{3}$							
$\frac{1}{4}$	$\frac{1}{4}$	$\frac{1}{4}$	$\frac{1}{4}$						
$\frac{1}{5}$	$\frac{1}{5}$	$\frac{1}{5}$	$\frac{1}{5}$	$\frac{1}{5}$					
$\frac{1}{6}$	$\frac{1}{6}$	$\frac{1}{6}$	$\frac{1}{6}$	$\frac{1}{6}$	$\frac{1}{6}$				
$\frac{1}{8}$	$\frac{1}{8}$	$\frac{1}{8}$	$\frac{1}{8}$	$\frac{1}{8}$	$\frac{1}{8}$	$\frac{1}{8}$			
$\frac{1}{9}$	$\frac{1}{9}$	$\frac{1}{9}$	$\frac{1}{9}$	$\frac{1}{9}$	$\frac{1}{9}$	$\frac{1}{9}$	$\frac{1}{9}$		
$\frac{1}{10}$	$\frac{1}{10}$	$\frac{1}{10}$	$\frac{1}{10}$	$\frac{1}{10}$	$\frac{1}{10}$	$\frac{1}{10}$	$\frac{1}{10}$	$\frac{1}{10}$	
$\frac{1}{12}$	$\frac{1}{12}$	$\frac{1}{12}$	$\frac{1}{12}$	$\frac{1}{12}$	$\frac{1}{12}$	$\frac{1}{12}$	$\frac{1}{12}$	$\frac{1}{12}$	$\frac{1}{12}$

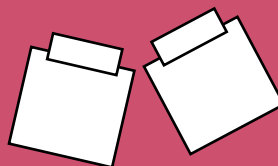
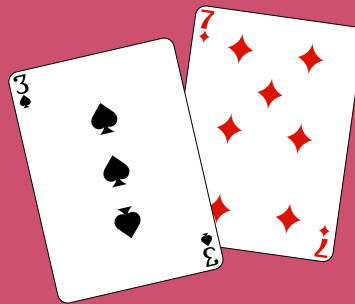
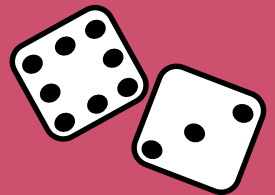
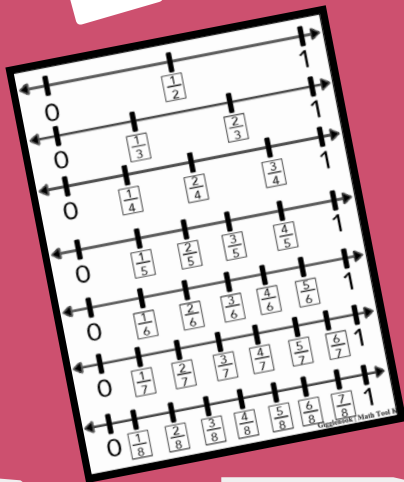
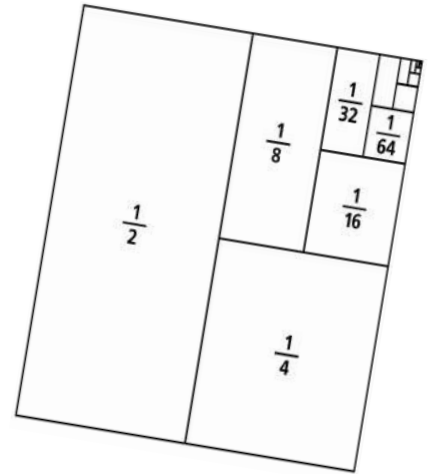
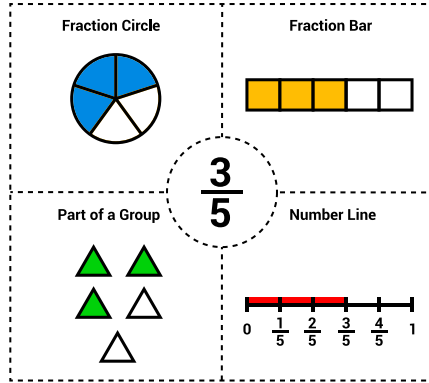

FRACTION TOOL KIT

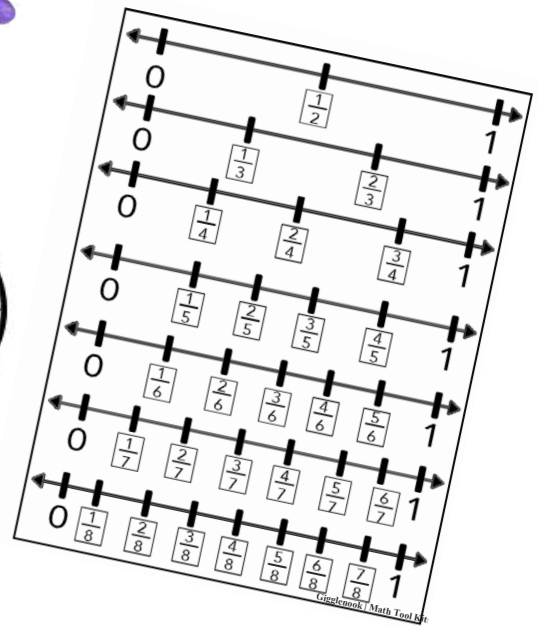
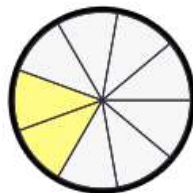
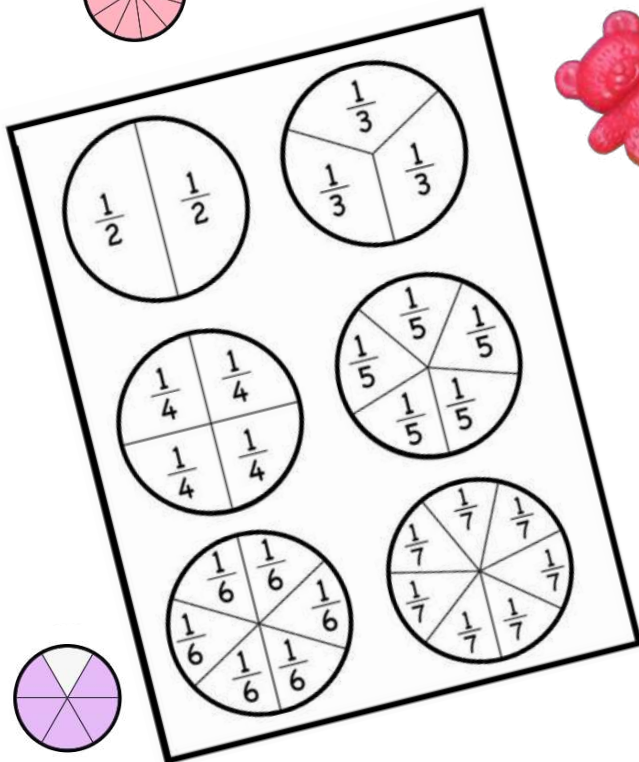

GUIDED MATH TEACHER'S FRACTION TOOLKIT

K-2

Dr. Nicki Newton



Math Fact Fluency Playground

Math Fact Fluency Playground
Email: drnicki@mathfactfluencyplayground.com
Website: Math Fact Fluency Playground
Produced by Math Fact Fluency Playground
Thank you to the entire Production

Copyright © Math Fact Fluency Playground

All rights reserved. No part of the book may be reproduced in any form, stored in a retrieval system, by any mechanical, photocopying, recording, scanning, electronic means, or otherwise under Section 107 or 108 of the 1976 United States Copyright Act, without prior written permission in writing from the publisher, except by a reviewer, who may quote brief passages in a review, with the exception of the reproducible, which may be photocopied for classroom use.

Permission is given to individual classroom teachers to reproduce the pages for classroom instruction use only. Reproduction of these materials for an entire school or district is strictly forbidden.

For additional copies of this publication or permission to reproduce this work, please contact Math Fact Fluency Playground.

Chief Operating Officer: Dr. Nicki Newton
Publisher: Math Fact Fluency Playground
Cover Design: Math Fact Fluency Playground Team
Text Design and Composition: Math Fact Fluency Playground Team

Printed in the United States of America
Volume 1: January 2024

CONTACT US



Dr. Nicki Newton

Email: drnicki@mathfactfluencyplayground.com

Website: www.mathfactfluencyplayground.com

Blog: guidedmath.wordpress.com

Other Books in this Series

Guided Math Teacher's Addition Toolkit

Guided Math Teacher's Decimal Toolkit

Guided Math Teacher's Division Toolkit

Guided Math Teacher's Hundred Grid Toolkit

Guided Math Teacher's Multiplication Toolkit

Guided Math Teacher's Number Paths,
Number Ladders, and Number Lines Toolkit

Guided Math Teacher's Subtraction Toolkit



Math Fact Fluency Playground

Dedicated to Mom and Pops, Always

CONTENTS

Acknowledgement	
Author's Note	
Fraction Circles	p.1
Number Lines Fraction	p.2
Fraction Circles	p.3
Fraction Squares	p.4
Pattern Blocks	p.7
Number Lines	p.14
Adding Fractions	p.16
Subtracting Fractions	p.18
Multiplying Fractions	p.20
Dividing Fractions	p.22
Comparing Fractions	p.24
Ordering Fractions	p.26
References	p.30

Math Fact Fluency Playground

Email: drnicki@mathfactfluencyplayground.com

Website: Math Fact Fluency Playground

Produced by Math Fact Fluency Playground

Thank you to the entire Production

Copyright © Math Fact Fluency Playground

All rights reserved. No part of the book may be reproduced in any form, stored in a retrieval system, by any mechanical, photocopying, recording, scanning, electronic means, or otherwise under Section 107 or 108 of the 1976 United States Copyright Act, without prior written permission in writing from the publisher, except by a reviewer, who may quote brief passages in a review, with the exception of the reproducible, which may be photocopied for classroom use.

Permission is given to individual classroom teachers to reproduce the pages for classroom instruction use only. Reproduction of these materials for an entire school or district is strictly forbidden.

For additional copies of this publication or permission to reproduce this work, please contact Math Fact Fluency Playground.

Chief Operating Officer: Dr. Nicki Newton

Publisher: Math Fact Fluency Playground

Cover Design: Math Fact Fluency Playground Team

Text Design and Composition: Math Fact Fluency Playground Team

Printed in the United States of America

Volume 1: January 2024

FRACTION CIRCLES

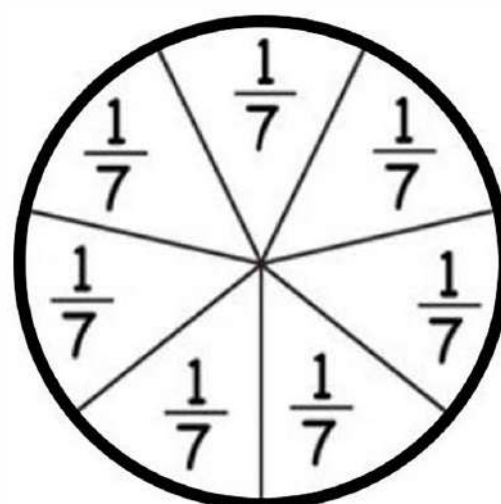
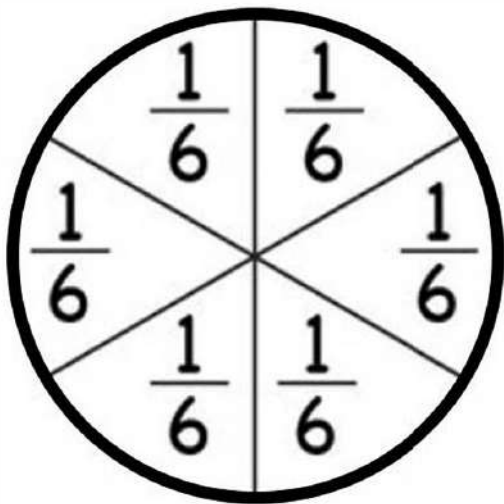
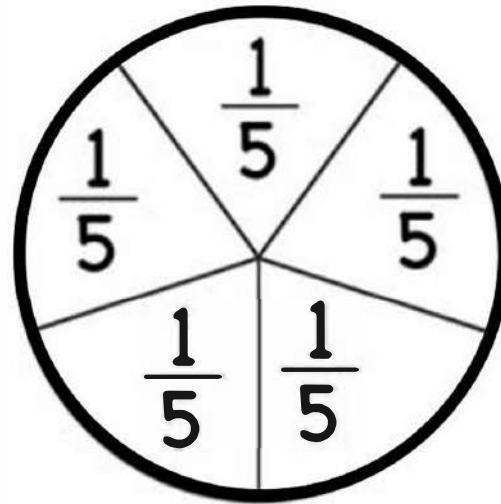
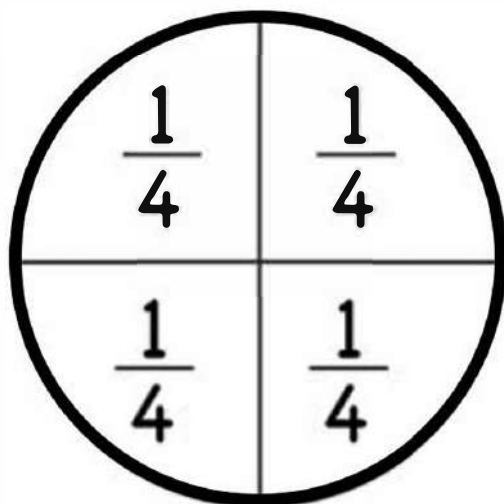
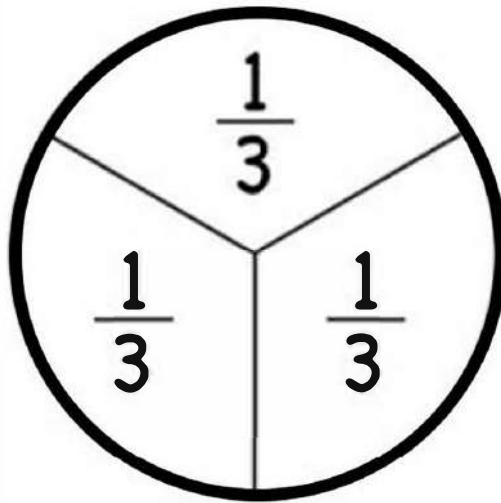
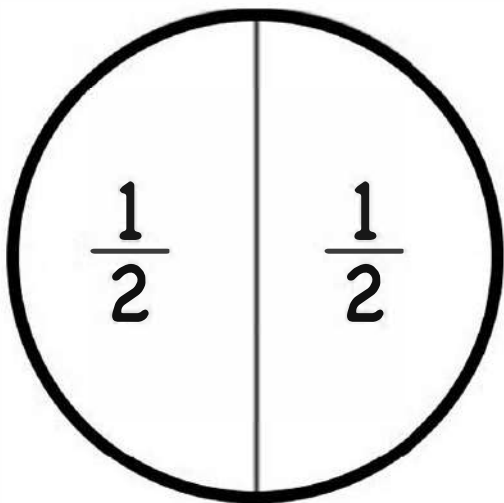

FRACTION CIRCLES

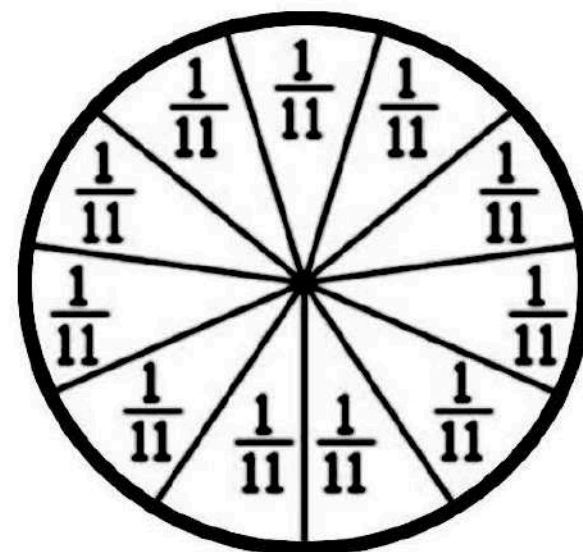
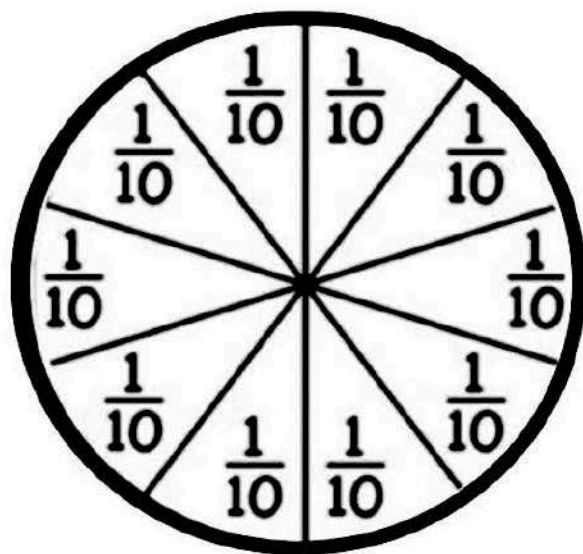
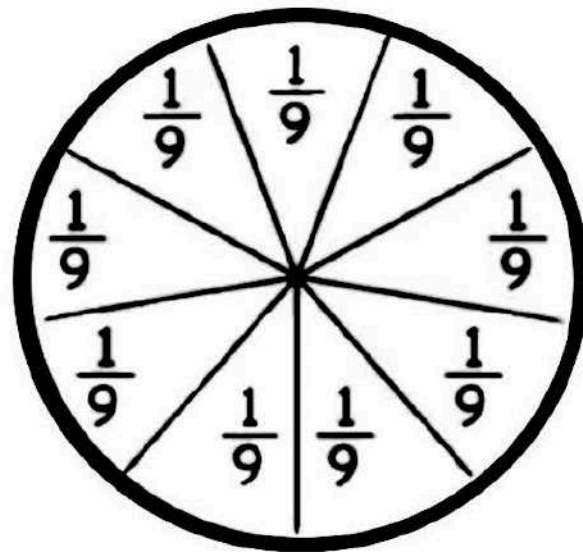
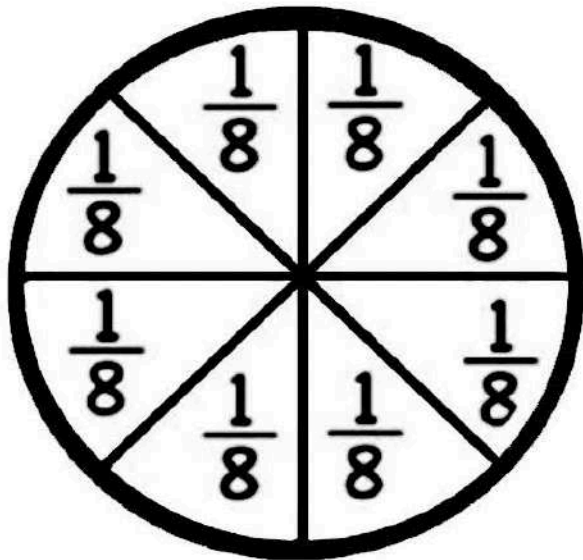

NUMBER LINES FRACTION

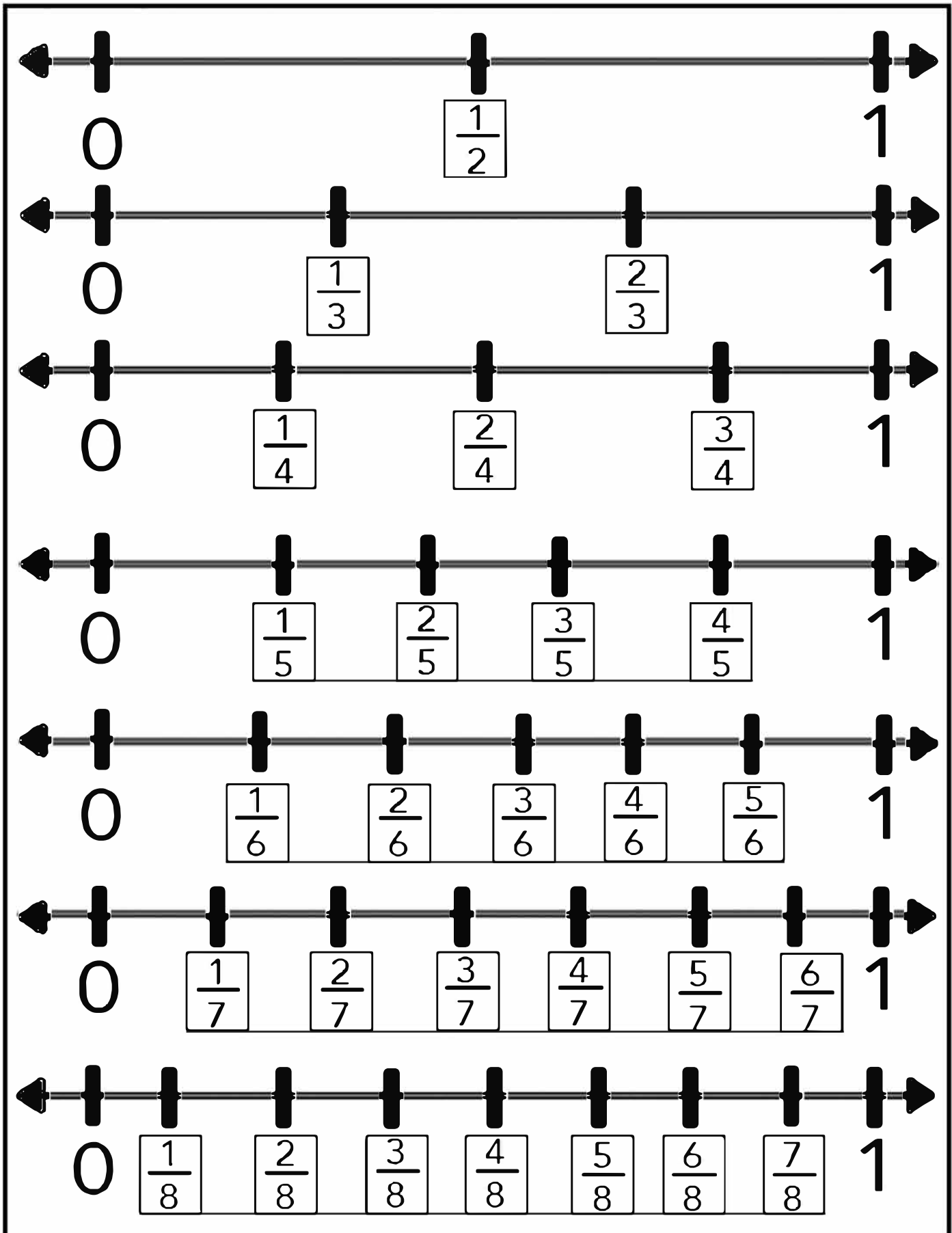

FRACTION CIRCLES

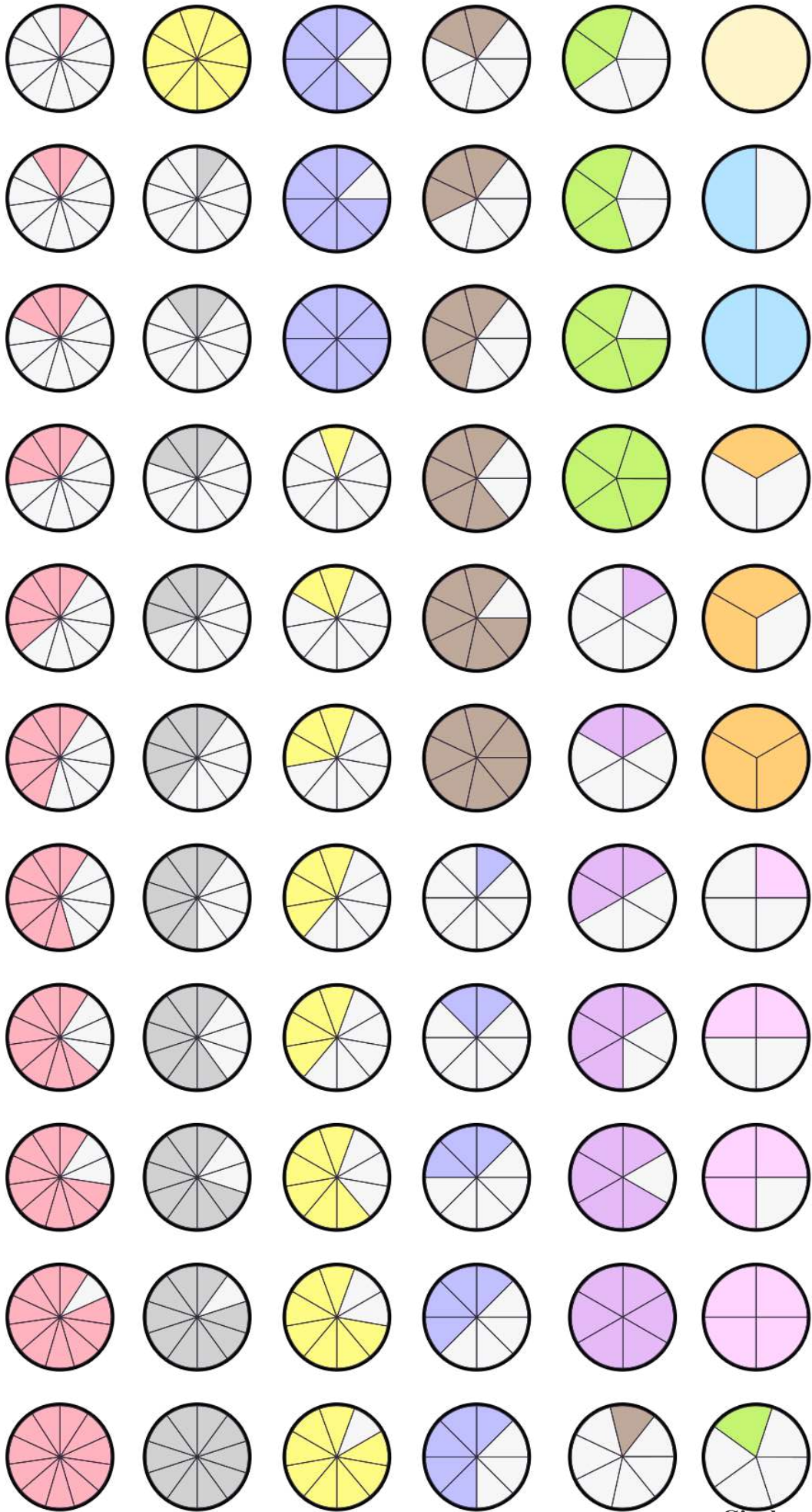

FRACTION SQUARES

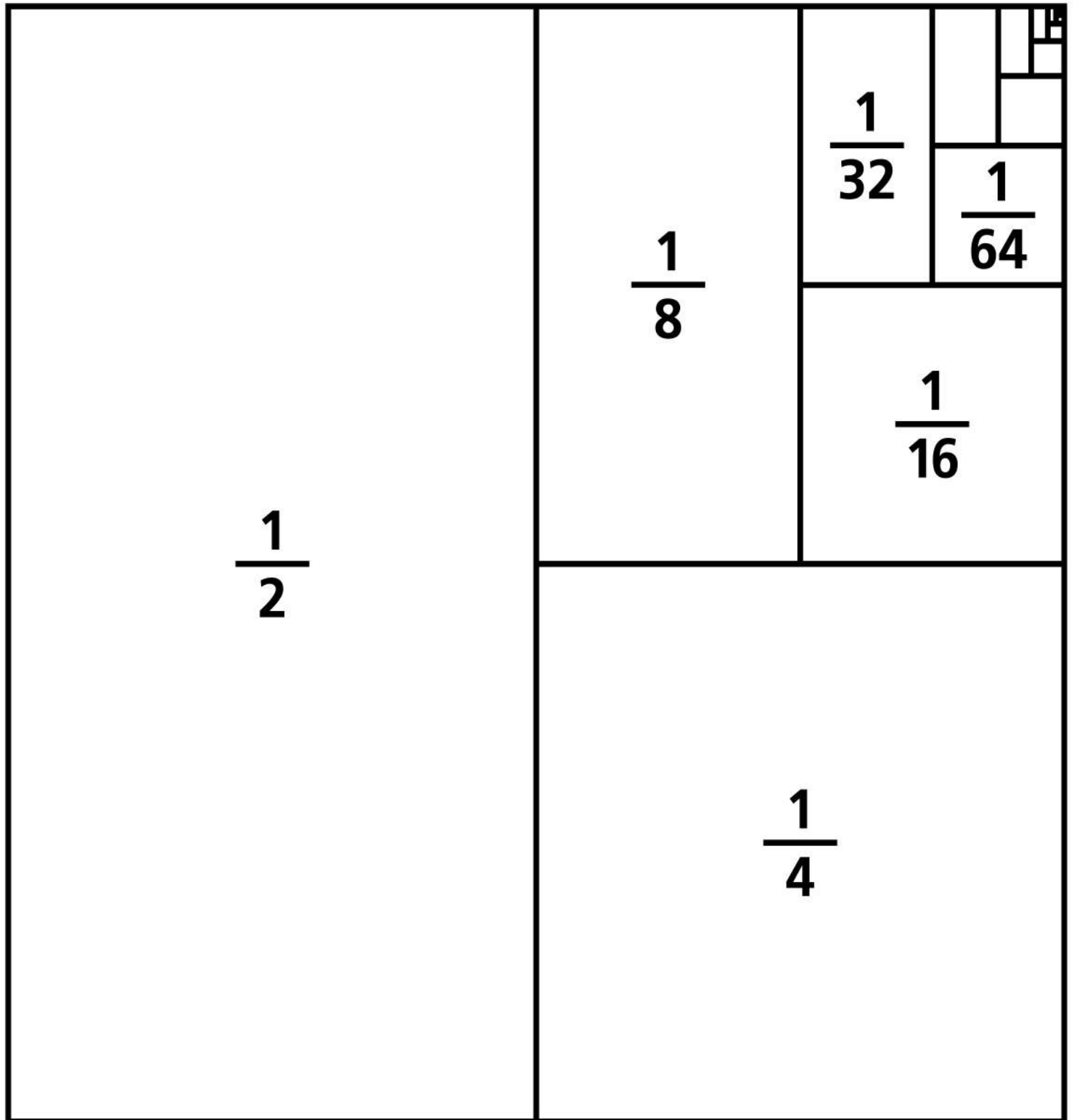

FRACTION SQUARES

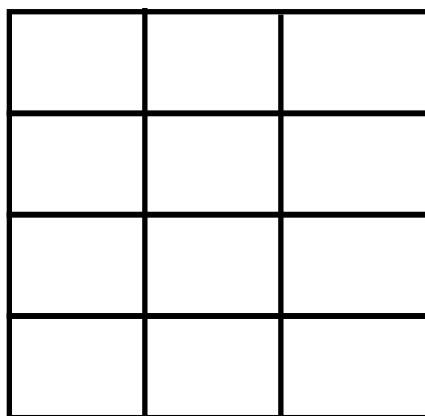
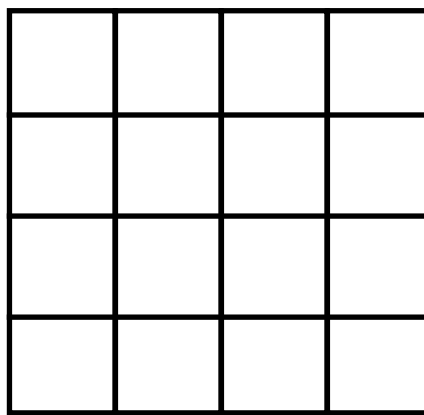
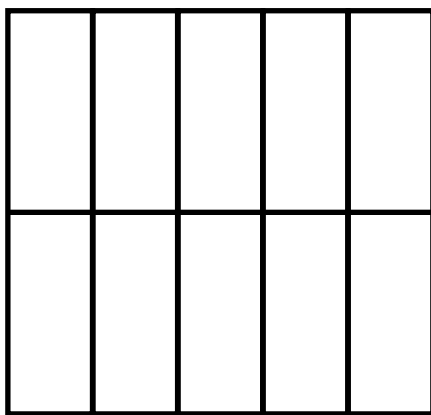
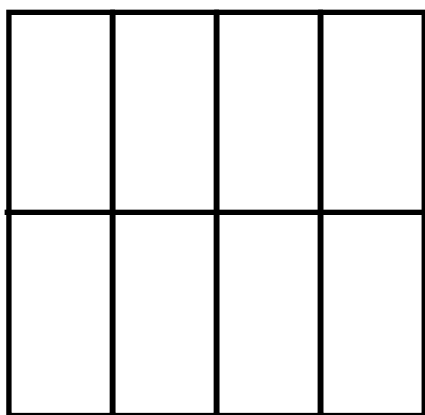
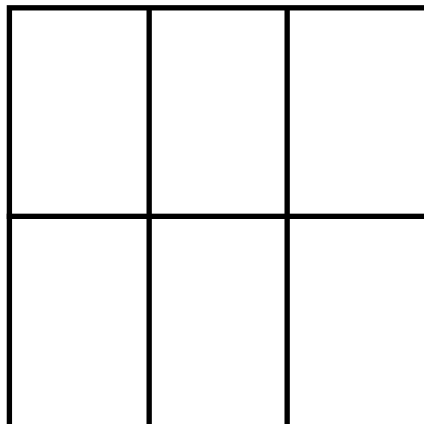
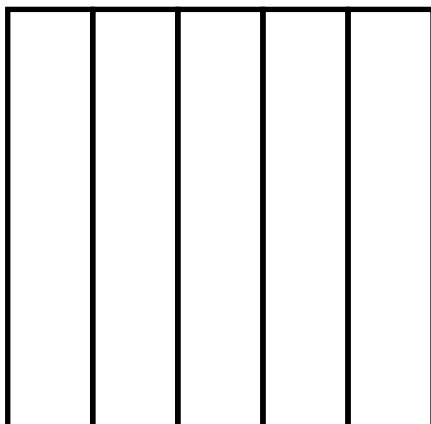
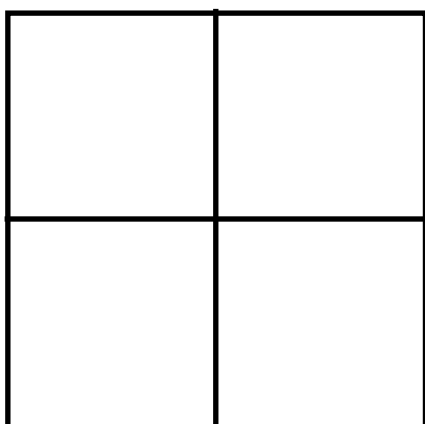
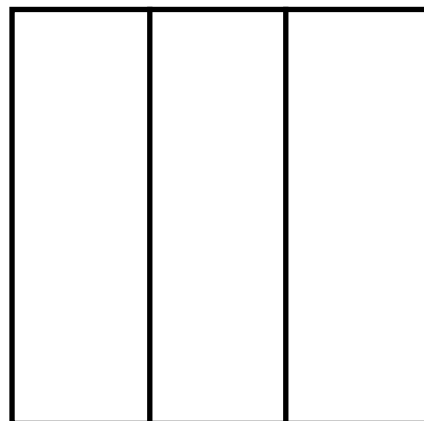
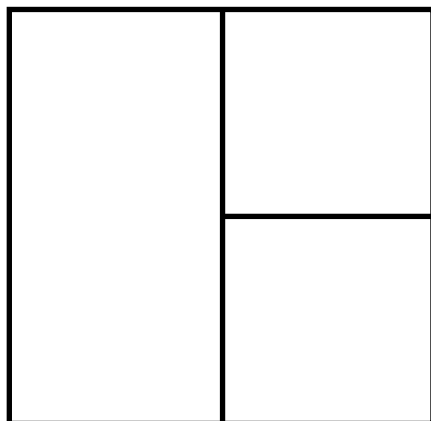
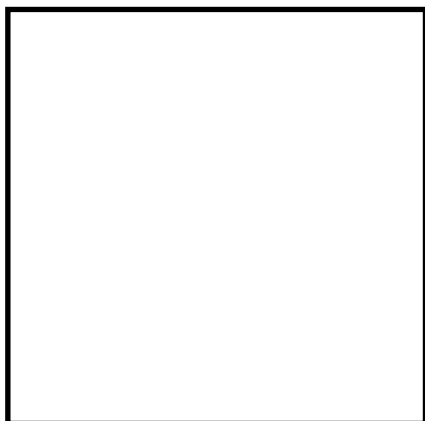

1

$\frac{1}{2}$

$\frac{1}{2}$

$\frac{1}{3}$

$\frac{1}{3}$

$\frac{1}{3}$

$\frac{1}{4}$

$\frac{1}{4}$

$\frac{1}{4}$

$\frac{1}{4}$

$\frac{1}{5}$

$\frac{1}{5}$

$\frac{1}{5}$

$\frac{1}{5}$

$\frac{1}{5}$

$\frac{1}{6}$

$\frac{1}{6}$

$\frac{1}{6}$

$\frac{1}{6}$

$\frac{1}{6}$

$\frac{1}{6}$

$\frac{1}{8}$

$\frac{1}{8}$

$\frac{1}{8}$

$\frac{1}{8}$

$\frac{1}{8}$

$\frac{1}{8}$

$\frac{1}{8}$

$\frac{1}{8}$

$\frac{1}{10}$

$\frac{1}{10}$

$\frac{1}{10}$

$\frac{1}{10}$

$\frac{1}{10}$

$\frac{1}{10}$

$\frac{1}{10}$

$\frac{1}{10}$

$\frac{1}{10}$

$\frac{1}{10}$

$\frac{1}{12}$

$\frac{1}{12}$

$\frac{1}{12}$

$\frac{1}{12}$

$\frac{1}{12}$

$\frac{1}{12}$

$\frac{1}{12}$

$\frac{1}{12}$

$\frac{1}{12}$

$\frac{1}{12}$

$\frac{1}{12}$

$\frac{1}{12}$

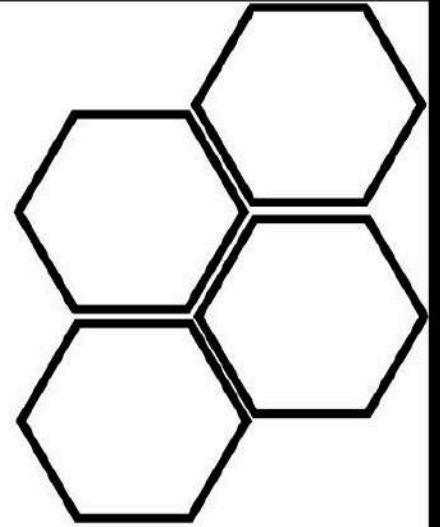
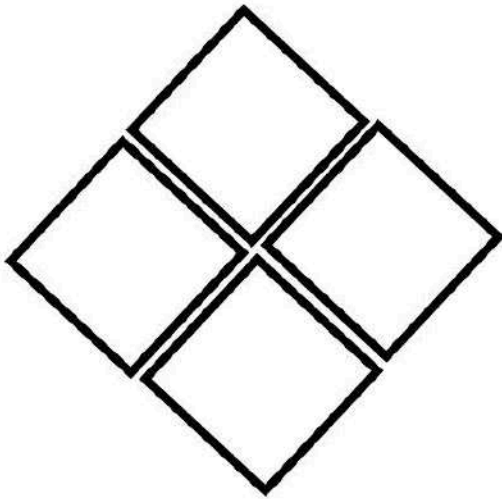

PATTERN BLOCKS

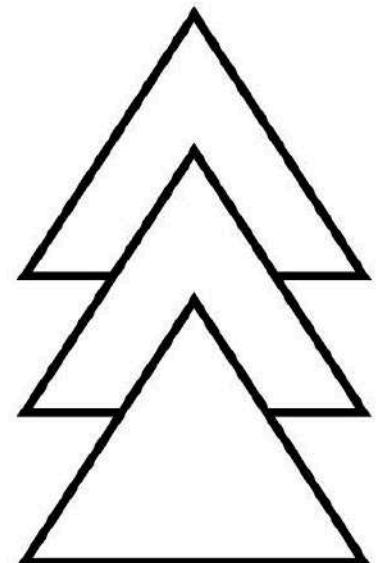
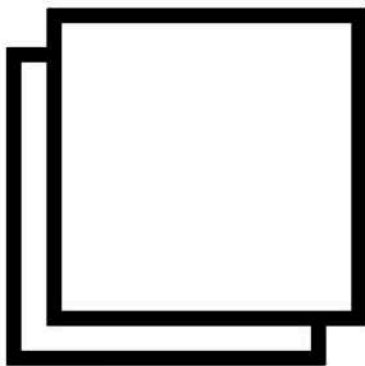
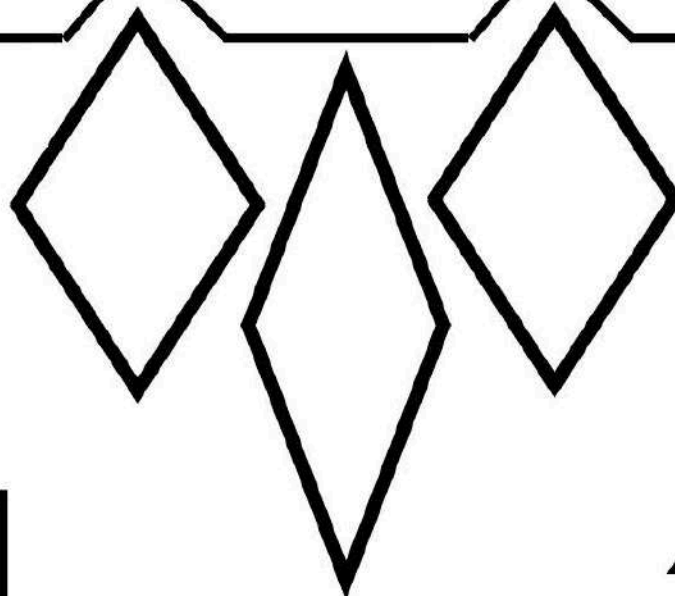

PATTERN BLOCKS

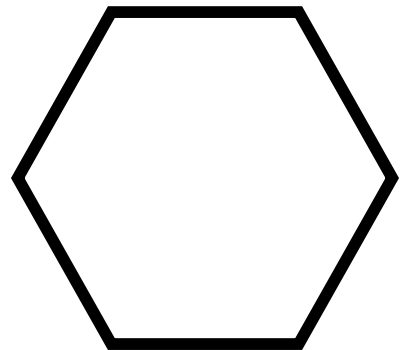
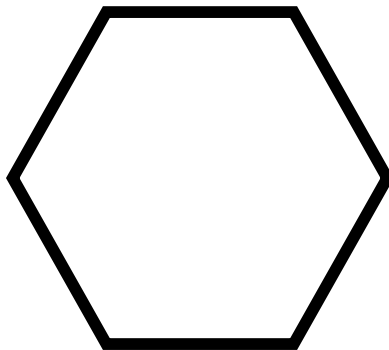
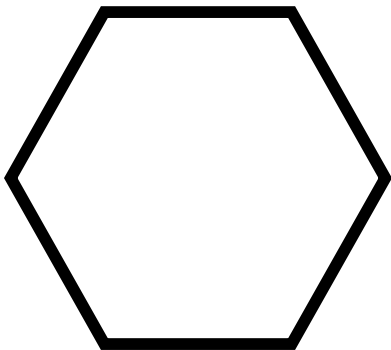
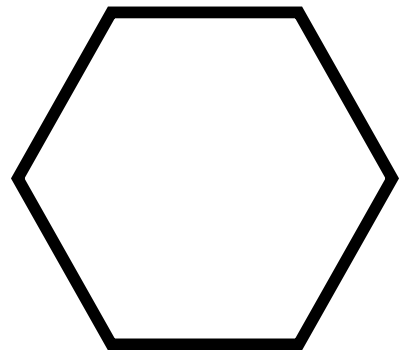
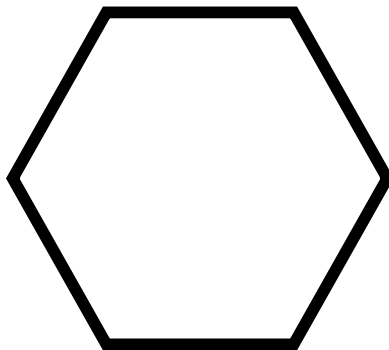
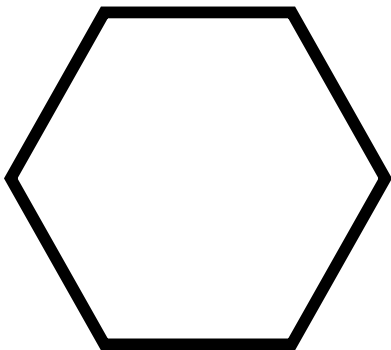
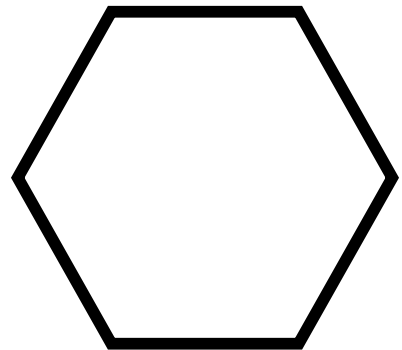
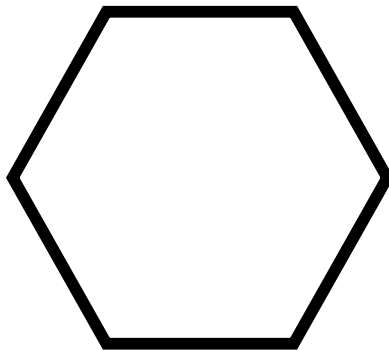
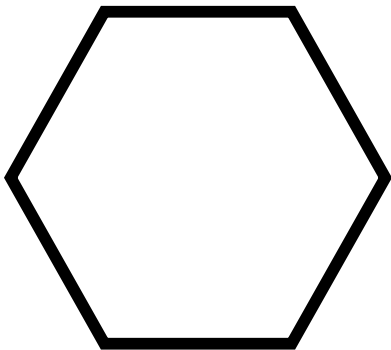
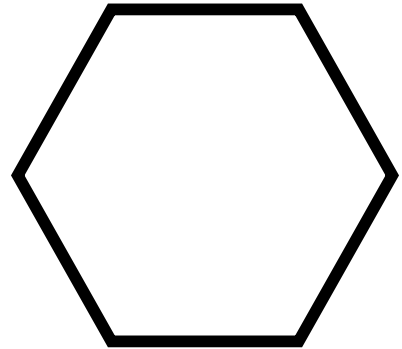
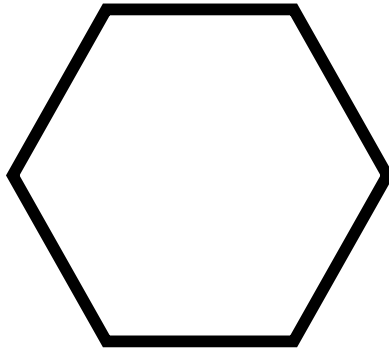
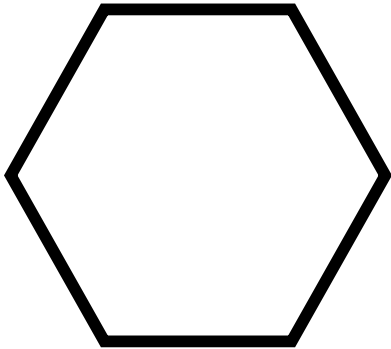

PATTERN BLOCKS

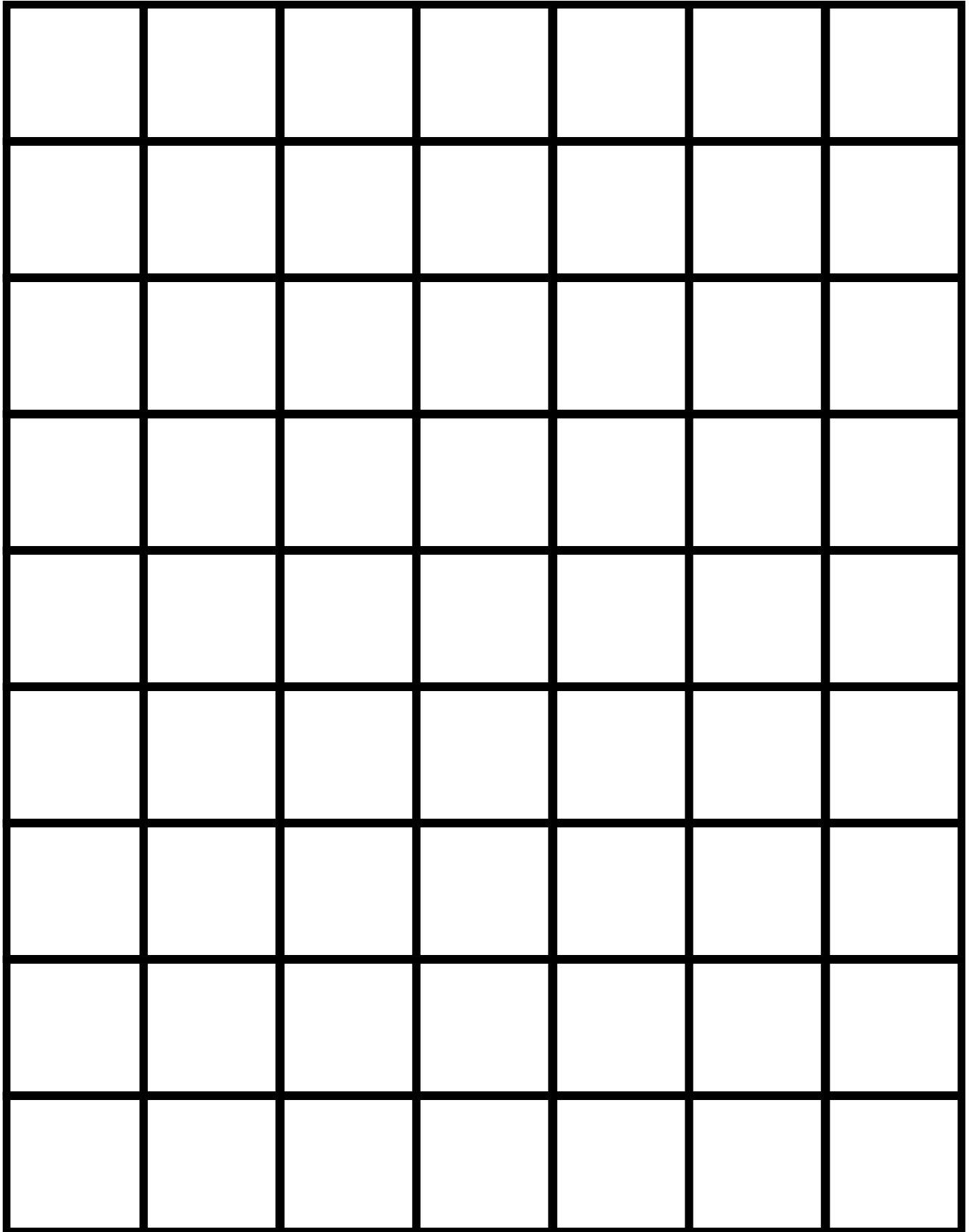

PATTERN BLOCKS

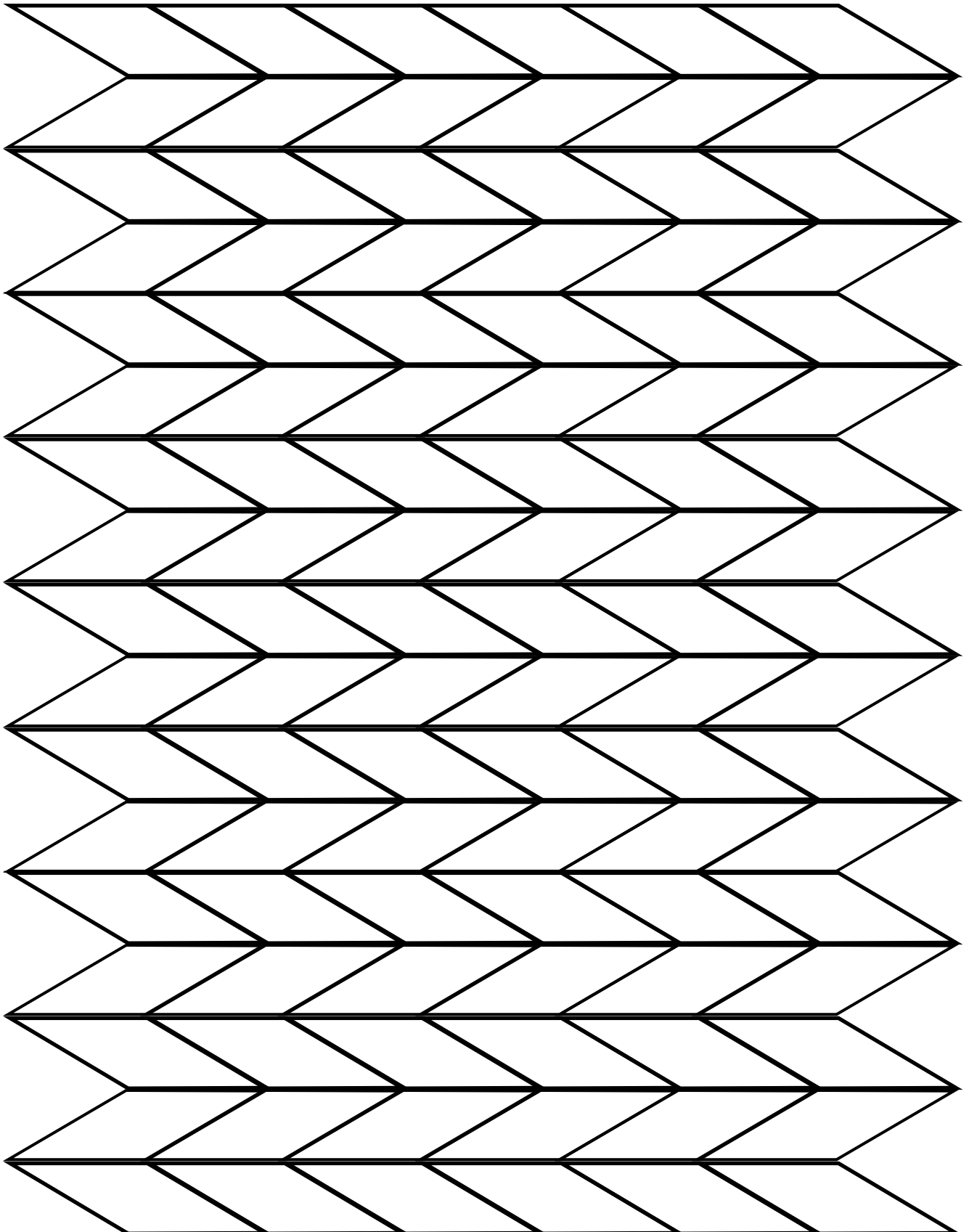

PATTERN BLOCKS

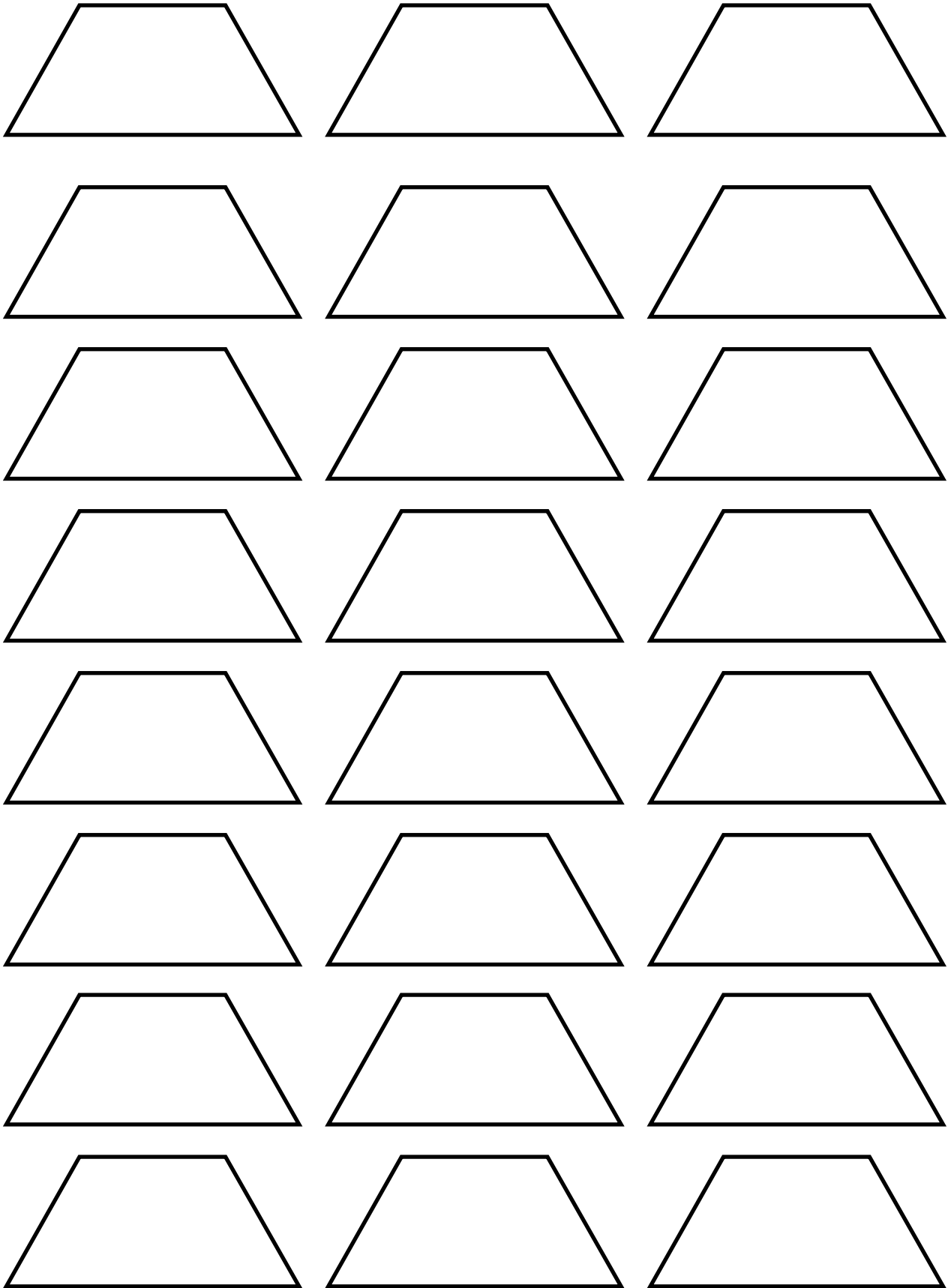

PATTERN BLOCKS

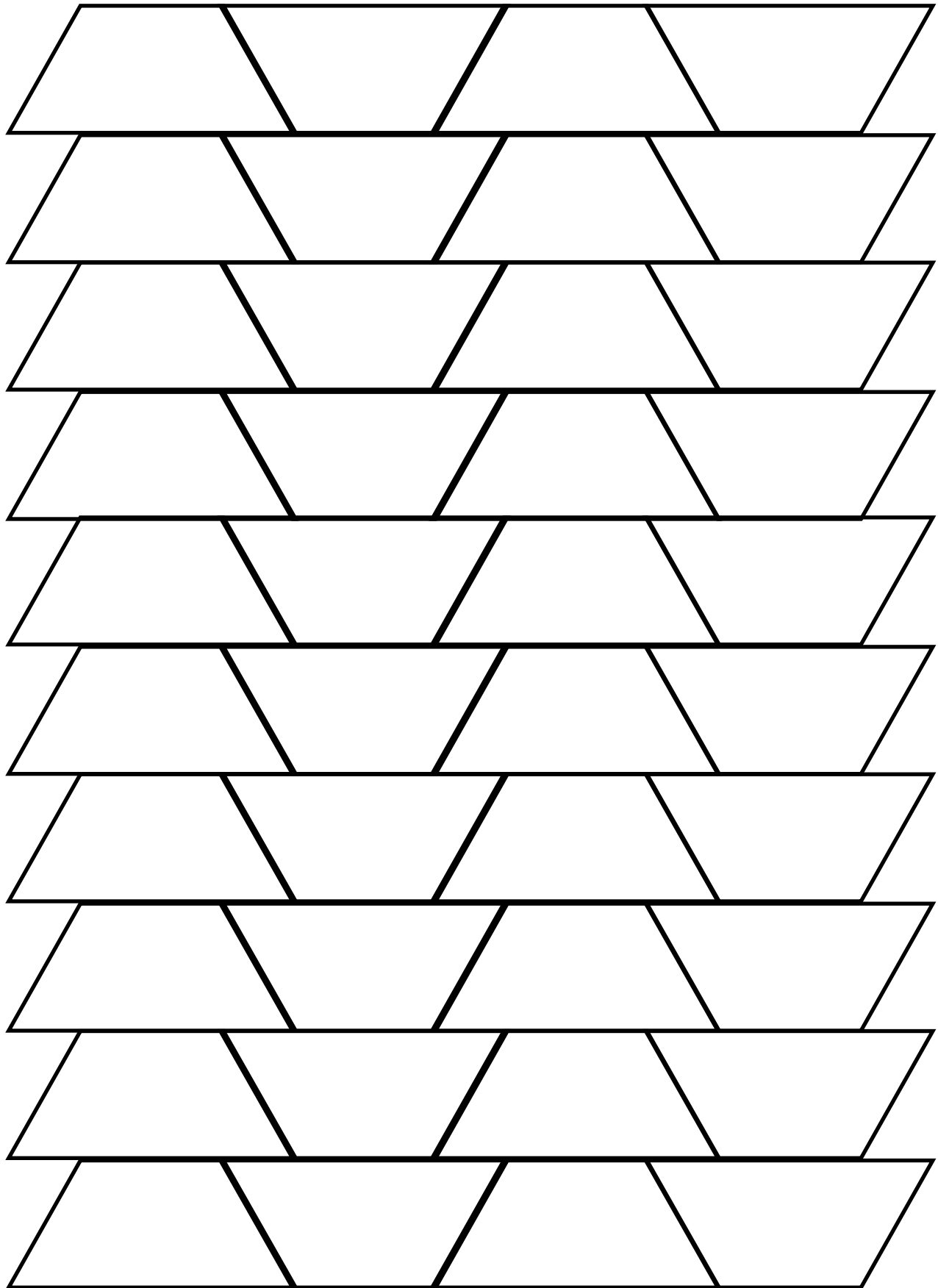

PATTERN BLOCKS

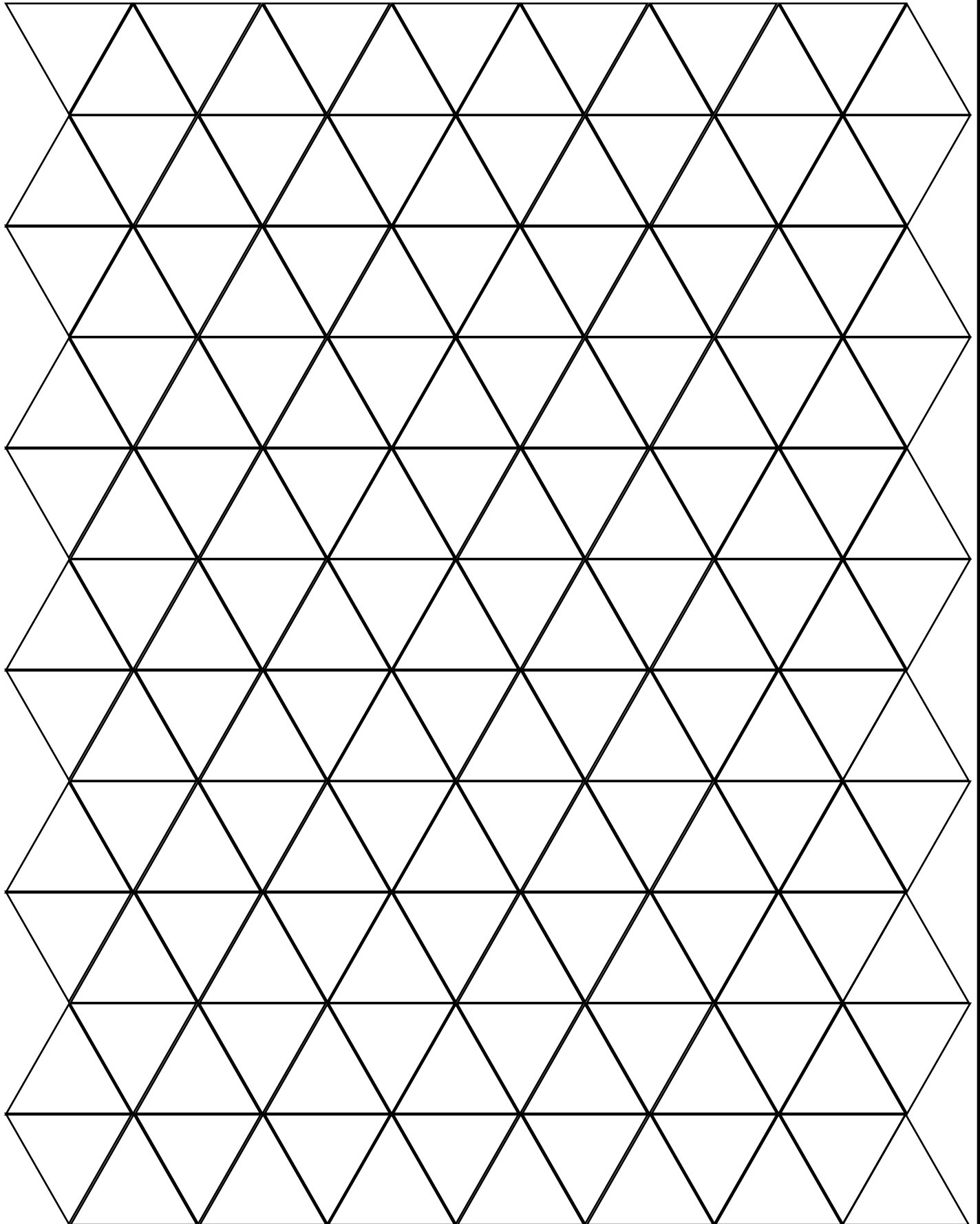

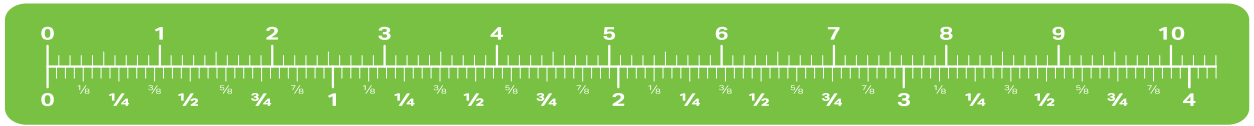
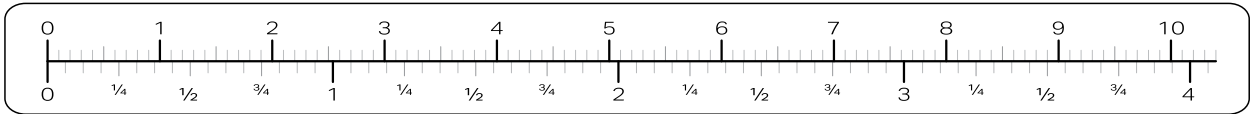

NUMBER LINES

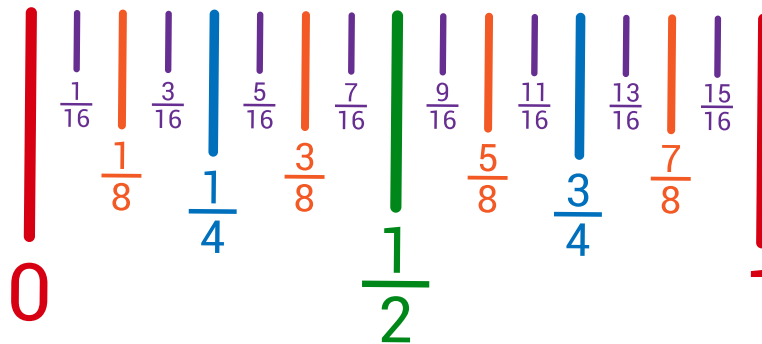

NUMBER LINES

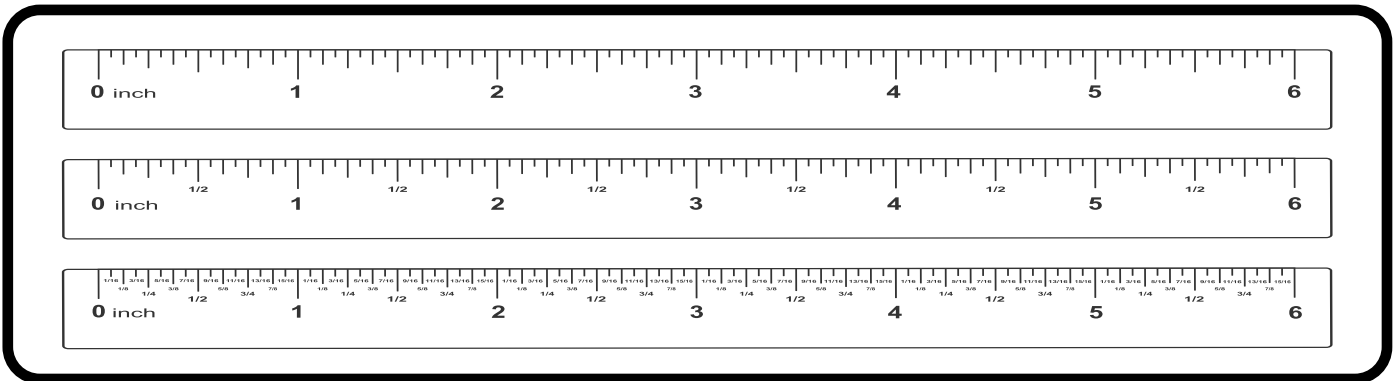
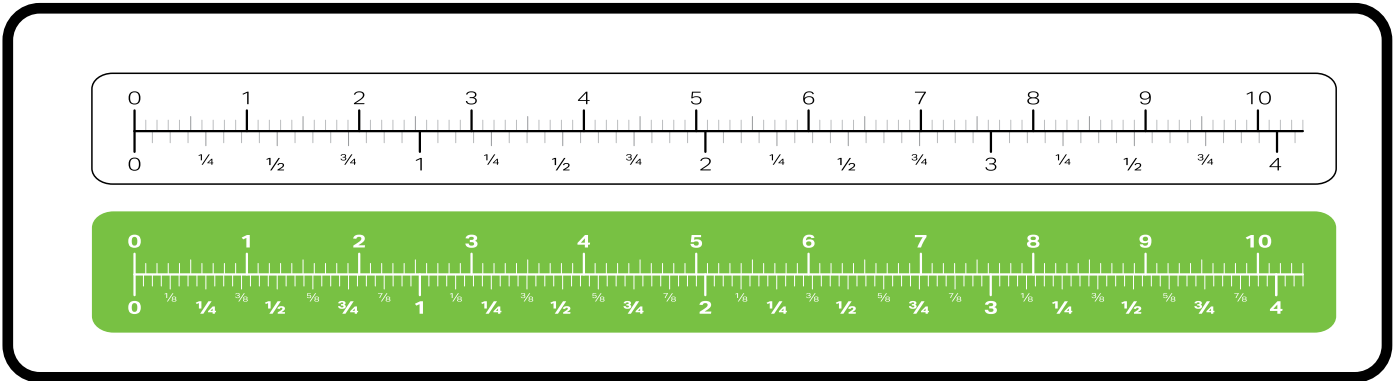
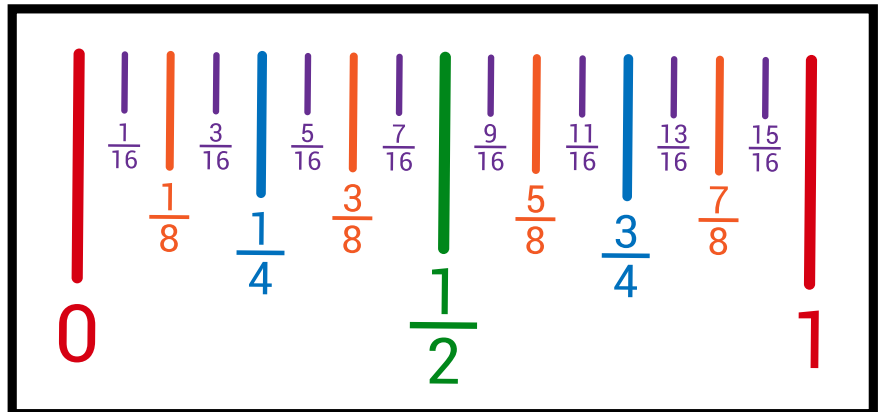
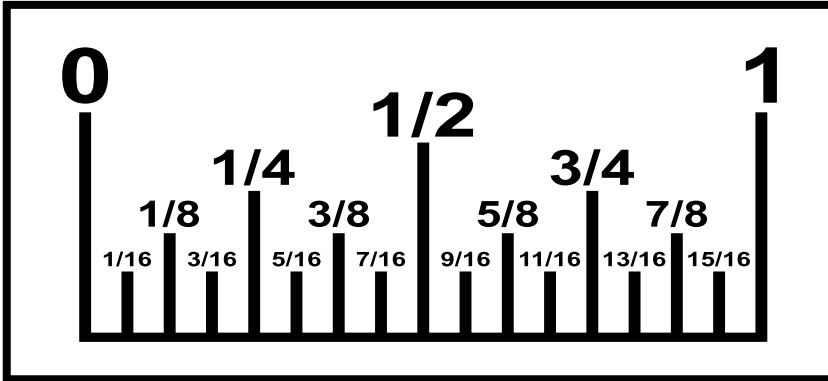

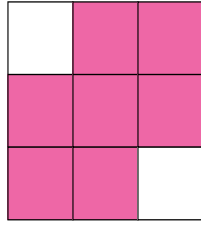
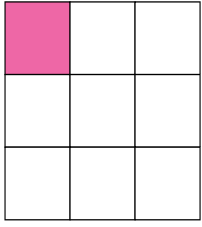

$$\frac{2}{4}$$

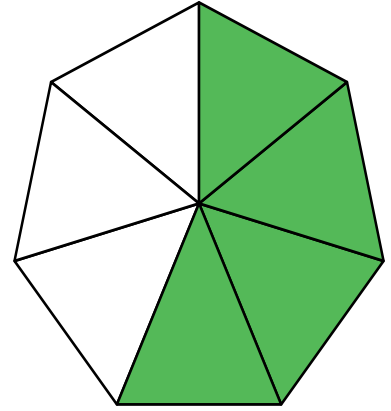

ADDING FRACTIONS

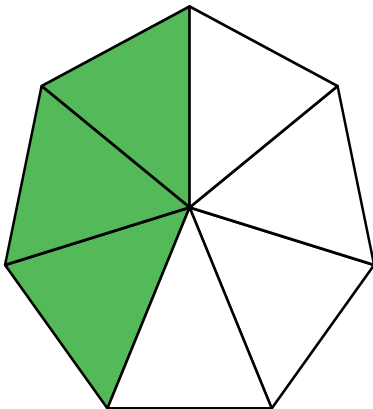
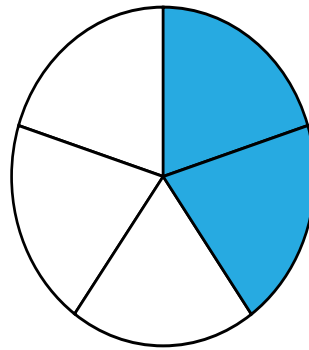

$$\frac{1}{4}$$

ADDING FRACTIONS

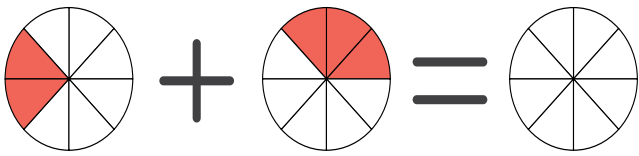

$$\frac{2}{8} + \frac{3}{8} = \frac{\square}{\square}$$



$$\frac{1}{6} + \frac{4}{6} = \frac{\square}{\square}$$

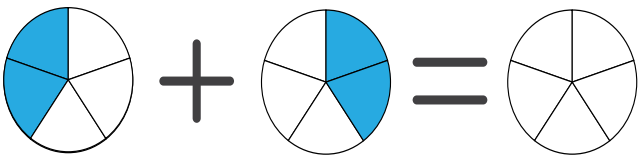

$$\frac{2}{5} + \frac{2}{5} = \frac{\square}{\square}$$

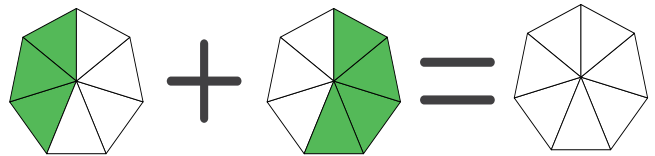

$$\frac{3}{7} + \frac{4}{7} = \frac{\square}{\square}$$

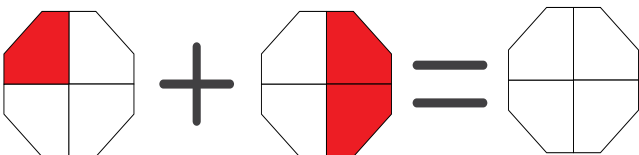

$$\frac{1}{4} + \frac{2}{4} = \frac{\square}{\square}$$

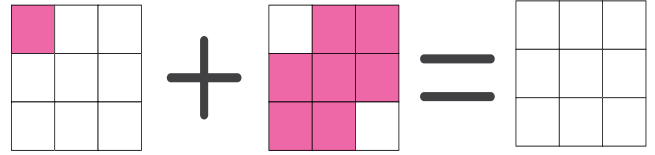

$$\frac{1}{9} + \frac{7}{9} = \frac{\square}{\square}$$

SUBTRACTING FRACTIONS

SUBTRACTING FRACTIONS

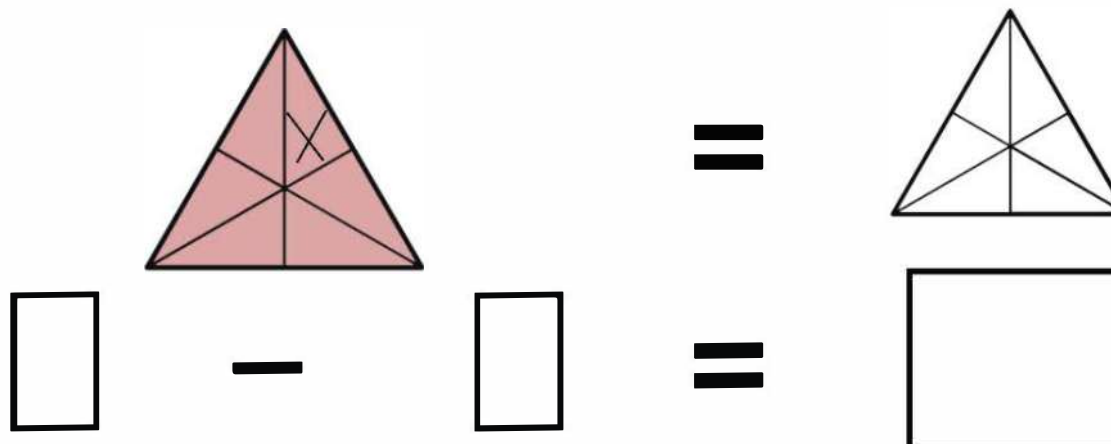
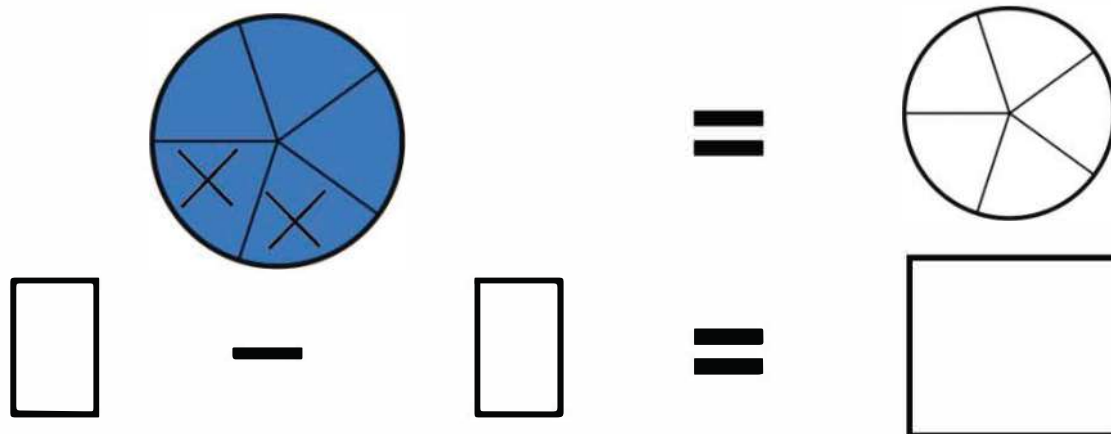
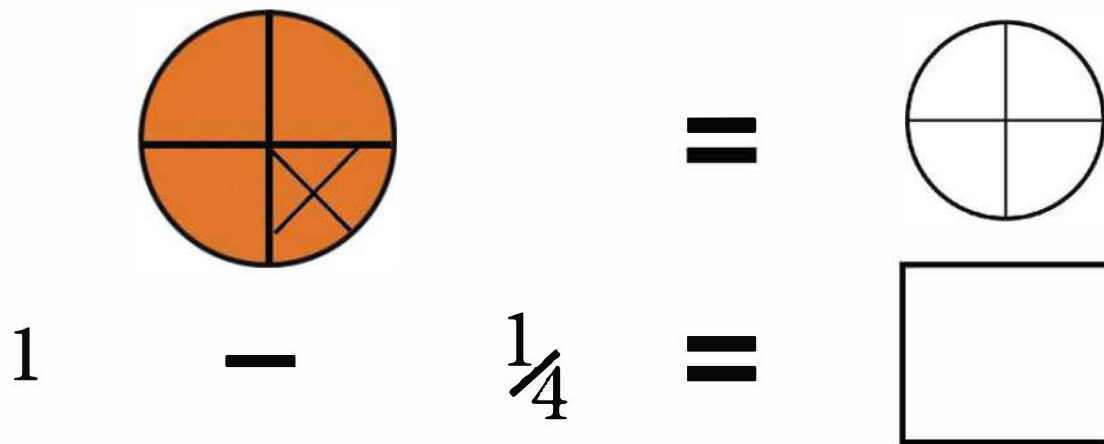

MULTIPLYING FRACTIONS

MULTIPLYING FRACTIONS

STEP 1

STEP 2

STEP 3

$$\frac{3}{4} \times \frac{2}{5}$$

$$= \frac{3 \times 2}{4 \times 5}$$

$$= \frac{6}{20}$$

simplify ?



problem

$$3 \times 1\frac{1}{2}$$

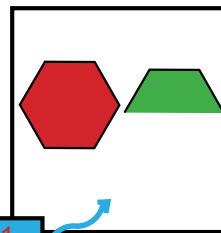
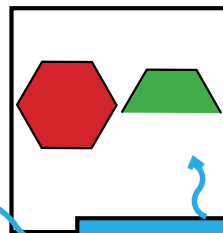
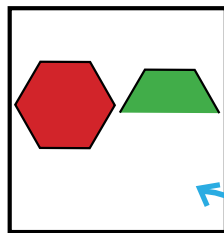

3 group of $1\frac{1}{2}$

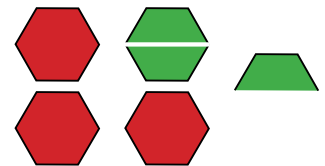

answer

$$4\frac{1}{2}$$

problem

$$3 \times \frac{2}{3}$$

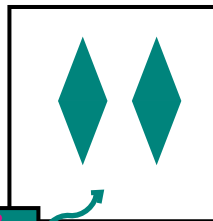
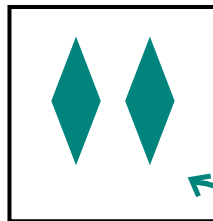

3 group of $\frac{2}{3}$



answer

$$\frac{6}{3} = 2$$

DIVIDING FRACTIONS

DIVIDING FRACTIONS

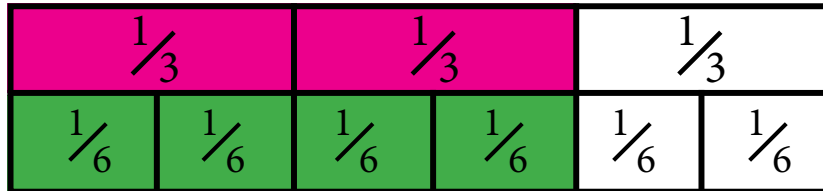

Visual Form

$$\frac{2}{3} \div \frac{1}{6} = 4$$

Symbolic Form

Tia Mary had $\frac{2}{3}$ of a cup of sugar. She wanted to make apple hand pies. She needed $\frac{1}{6}$ of a cup for each hand pie. How many hand pies can she make?

Story Form

COMPARING FRACTIONS

COMPARING FRACTIONS

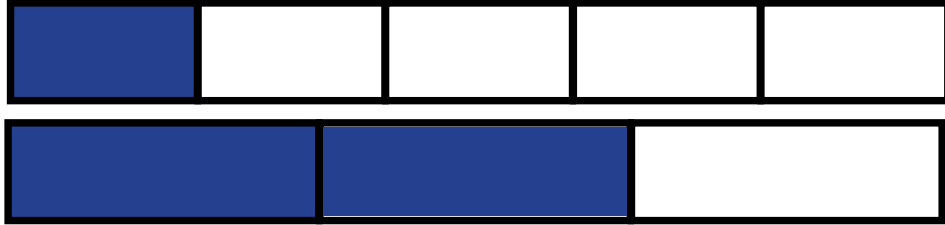

$$\frac{1}{5} < \frac{2}{3}$$



$$\frac{2}{3} > \frac{3}{5}$$

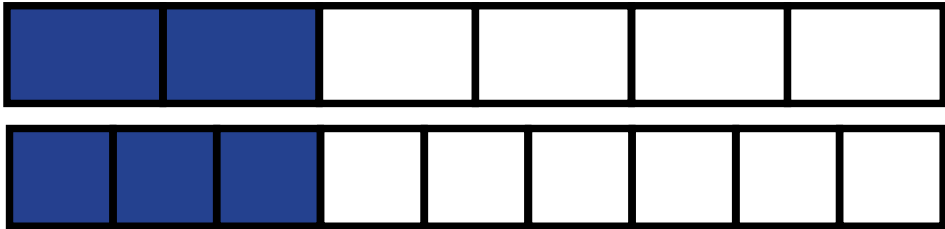

$$\frac{2}{6} = \frac{3}{9}$$

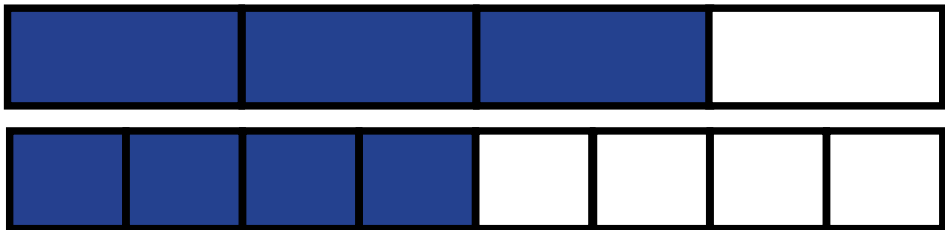

$$\frac{3}{4} > \frac{4}{8}$$

ORDERING FRACTIONS

ORDERING FRACTIONS

A. Cut apart the little cards and order them from least to greatest.

$$\frac{1}{2}$$

$$\frac{1}{4}$$

$$\frac{8}{4}$$

$$\frac{3}{8}$$

A. Cut apart the little cards and order them from least to greatest.

$$\frac{3}{4}$$

$$\frac{1}{2}$$

$$\frac{6}{8}$$

$$4\frac{1}{2}$$

A. Cut apart the little cards and order them from least to greatest.

$$\frac{2}{6}$$

$$\frac{2}{3}$$

$$1\frac{1}{2}$$

$$2\frac{1}{2}$$

EQUIVALENT FRACTIONS

EQUIVALENT FRACTIONS

A. Circle the equivalent fractions that you see. Explain why they are equivalent.

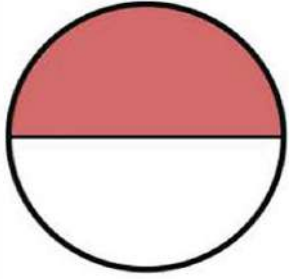

$$\frac{1}{2}$$

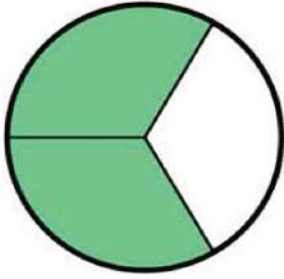

$$\frac{2}{3}$$

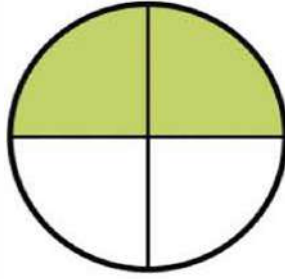

$$\frac{2}{4}$$

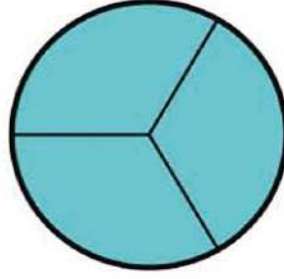

$$\frac{3}{3}$$

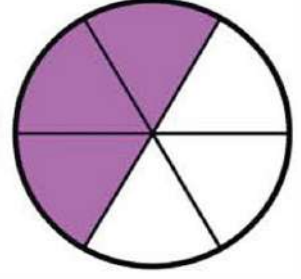

$$\frac{3}{6}$$

B. Circle the equivalent fractions that you see. Explain why they are equivalent.

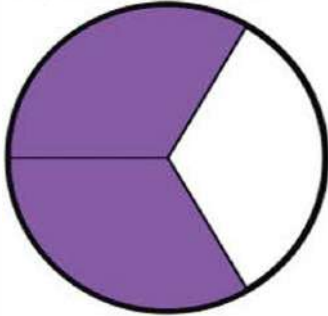

$$\frac{2}{3}$$

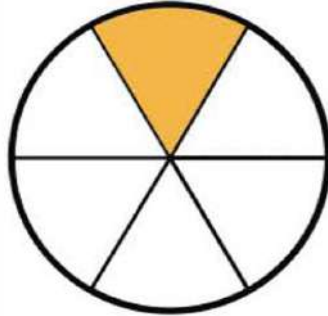

$$\frac{1}{6}$$

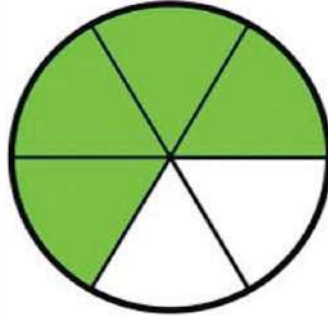

$$\frac{4}{6}$$

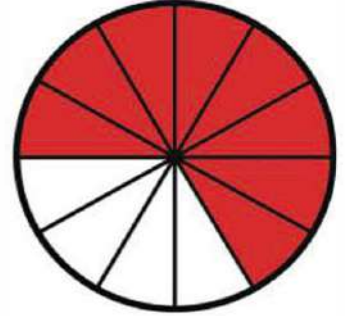

$$\frac{8}{12}$$

C. Circle the equivalent fractions that you see. Explain why they are equivalent.

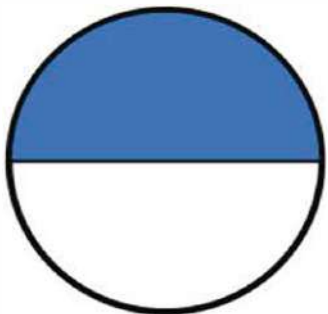

$$\frac{1}{2}$$

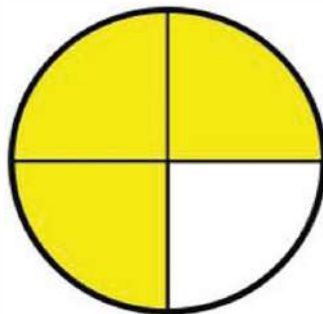

$$\frac{3}{4}$$

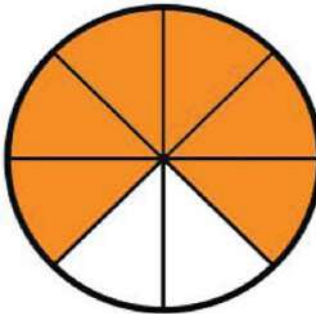

$$\frac{6}{8}$$

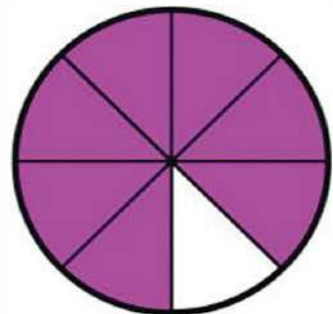

$$\frac{7}{8}$$

GAMES

FRACTION BOARD GAME

Instructions: Roll the dice. Move and solve the problem. Whoever reaches the end first wins!

I can multiply fractions!

The board game path consists of the following multiplication problems in order from start to finish:

START	START
$\frac{5}{9} \times \frac{6}{8}$	$\frac{5}{9} \times \frac{6}{8}$
$\frac{5}{10} \times \frac{3}{7}$	$\frac{5}{10} \times \frac{3}{7}$
$\frac{2}{7} \times \frac{4}{6}$	$\frac{2}{7} \times \frac{4}{6}$
$\frac{1}{5} \times \frac{4}{7}$	$\frac{5}{9} \times \frac{6}{7}$
$\frac{5}{8} \times \frac{6}{7}$	$\frac{2}{7} \times \frac{4}{6}$
$\frac{5}{8} \times \frac{6}{7}$	$\frac{1}{5} \times \frac{4}{7}$
$\frac{2}{5} \times \frac{5}{8}$	$\frac{5}{9} \times \frac{6}{7}$
$\frac{3}{4} \times \frac{7}{10}$	$\frac{2}{7} \times \frac{4}{6}$
$\frac{7}{9} \times \frac{4}{8}$	$\frac{6}{8} \times \frac{3}{6}$
$\frac{6}{8} \times \frac{3}{6}$	$\frac{4}{6} \times \frac{3}{5}$
$\frac{7}{9} \times \frac{4}{8}$	$\frac{7}{9} \times \frac{9}{10}$
$\frac{7}{9} \times \frac{4}{8}$	$\frac{2}{10} \times \frac{4}{5}$
$\frac{6}{8} \times \frac{3}{6}$	$\frac{7}{9} \times \frac{5}{7}$
$\frac{4}{6} \times \frac{3}{5}$	$\frac{7}{9} \times \frac{5}{7}$
$\frac{7}{9} \times \frac{9}{10}$	$\frac{3}{5} \times \frac{3}{6}$
$\frac{2}{10} \times \frac{4}{5}$	$\frac{3}{5} \times \frac{3}{6}$
$\frac{7}{9} \times \frac{5}{7}$	$\frac{6}{7} \times \frac{2}{5}$
$\frac{3}{5} \times \frac{3}{6}$	$\frac{6}{7} \times \frac{2}{5}$
$\frac{6}{7} \times \frac{2}{5}$	$\frac{6}{7} \times \frac{2}{5}$
$\frac{6}{7} \times \frac{2}{5}$	$\frac{4}{7} \times \frac{7}{9}$
$\frac{4}{7} \times \frac{7}{9}$	$\frac{4}{7} \times \frac{7}{9}$
$\frac{4}{7} \times \frac{7}{9}$	$\frac{4}{7} \times \frac{7}{9}$
$\frac{6}{7} \times \frac{3}{8}$	$\frac{6}{7} \times \frac{3}{8}$
$\frac{6}{7} \times \frac{3}{8}$	$\frac{6}{7} \times \frac{3}{8}$
$\frac{7}{8} \times \frac{4}{3}$	$\frac{7}{8} \times \frac{4}{3}$
$\frac{3}{5} \times \frac{2}{4}$	$\frac{3}{5} \times \frac{2}{4}$
$\frac{1}{6} \times \frac{1}{2}$	$\frac{1}{6} \times \frac{1}{2}$
$\frac{5}{6} \times \frac{7}{10}$	$\frac{5}{6} \times \frac{7}{10}$
$\frac{3}{9} \times \frac{8}{9}$	$\frac{3}{9} \times \frac{8}{9}$
$\frac{3}{9} \times \frac{8}{9}$	$\frac{3}{9} \times \frac{8}{9}$
$\frac{3}{9} \times \frac{8}{9}$	$\frac{3}{9} \times \frac{8}{9}$
$\frac{3}{9} \times \frac{8}{9}$	$\frac{3}{9} \times \frac{8}{9}$
$\frac{3}{9} \times \frac{8}{9}$	$\frac{3}{9} \times \frac{8}{9}$



Instructions: Roll the dice. Move and solve the problem. Whoever reaches the end first wins!

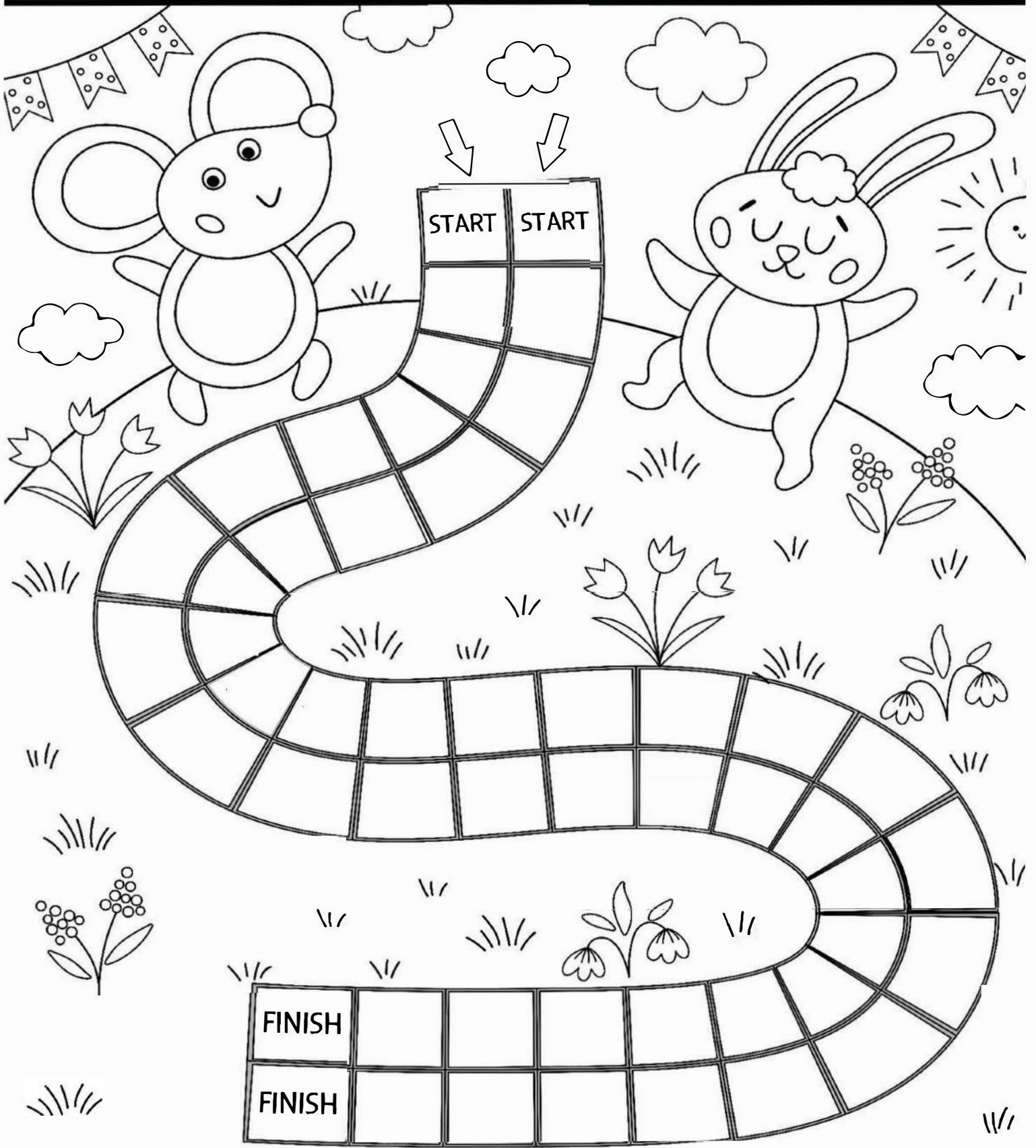
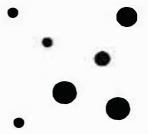

1	2	3	4	5	6	7	8	9	10
---	---	---	---	---	---	---	---	---	----

Gigglebook 2021

SPINNER

Use these cards for different games to compare, make equivalent fractions, add, subtraction, multiply and divide.

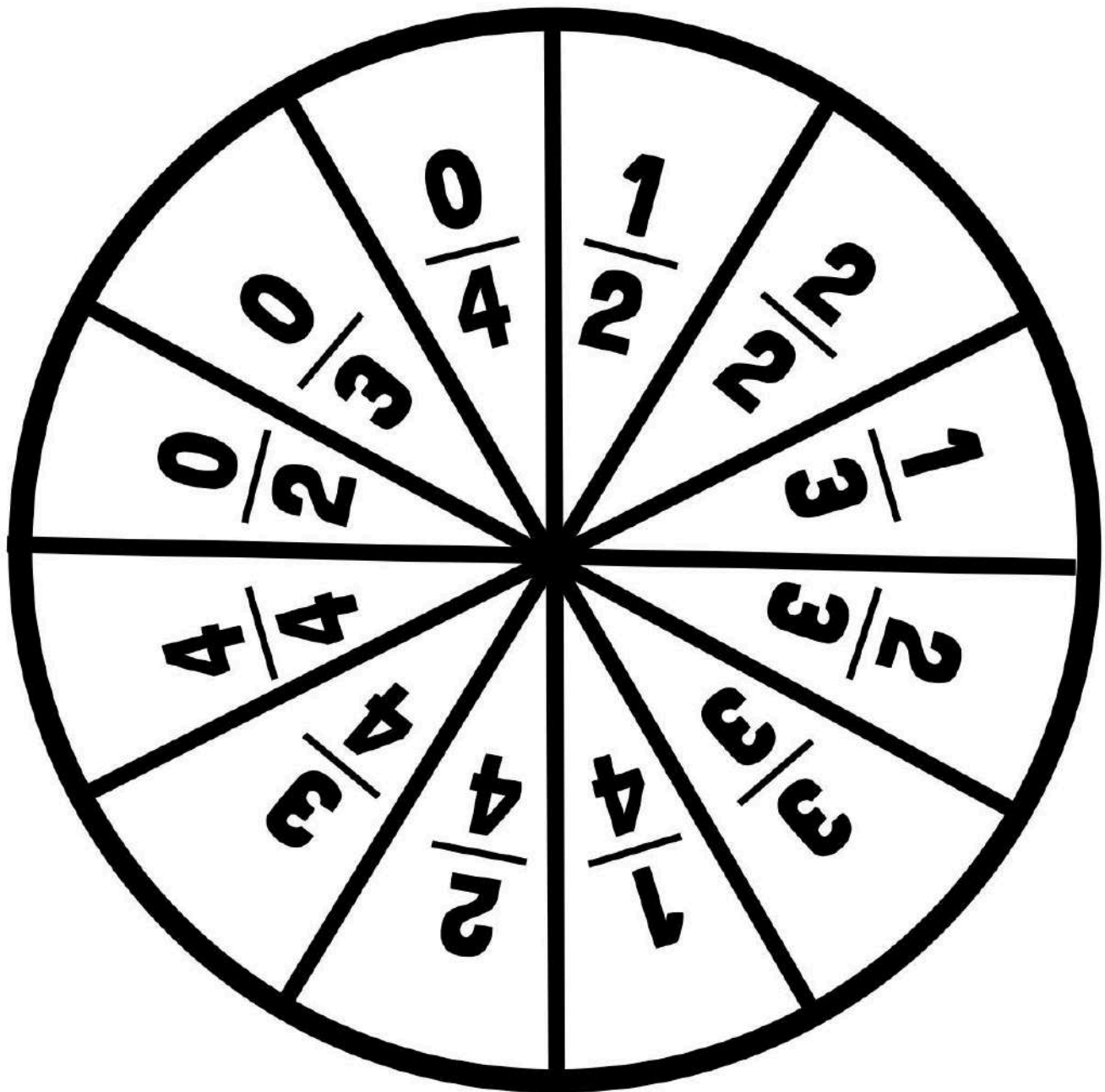

SPINNER

Use these cards for different games to compare, make equivalent fractions, add, subtraction, multiply and divide.

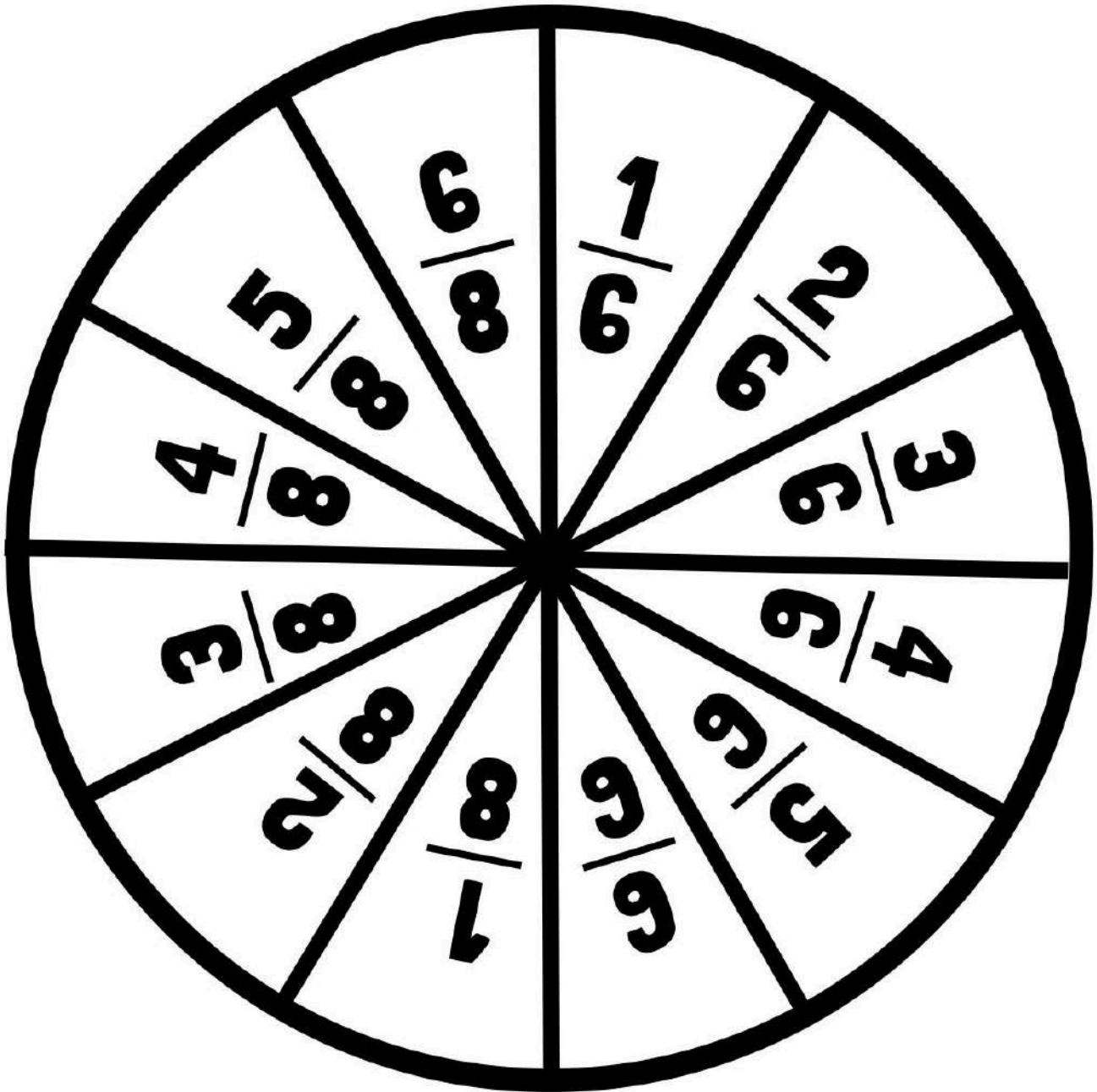

SPINNER

Use these cards for different games to compare, make equivalent fractions, add, subtraction, multiply and divide.

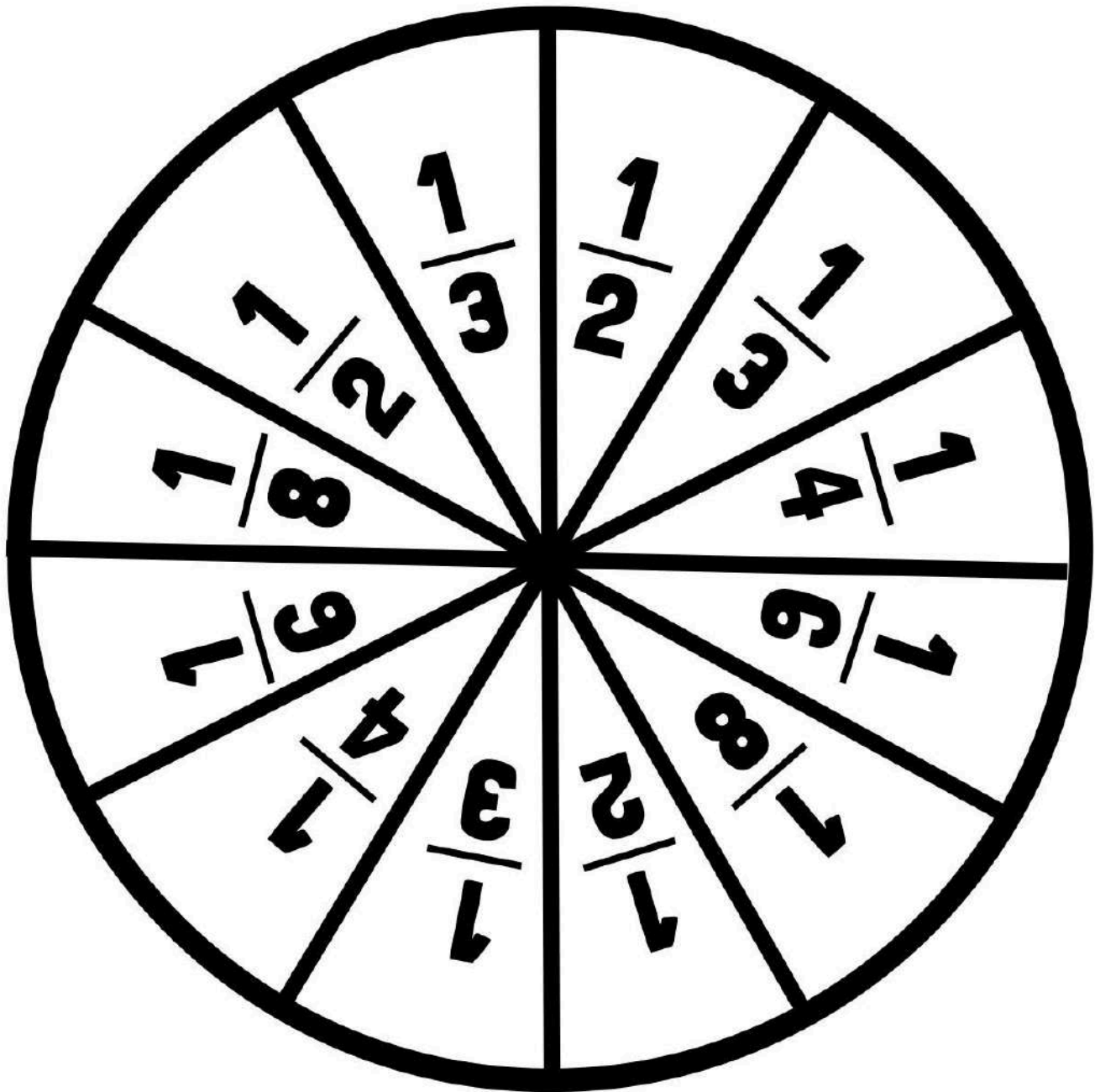

SPINNER

Use these cards for different games to compare, make equivalent fractions, add, subtraction, multiply and divide.

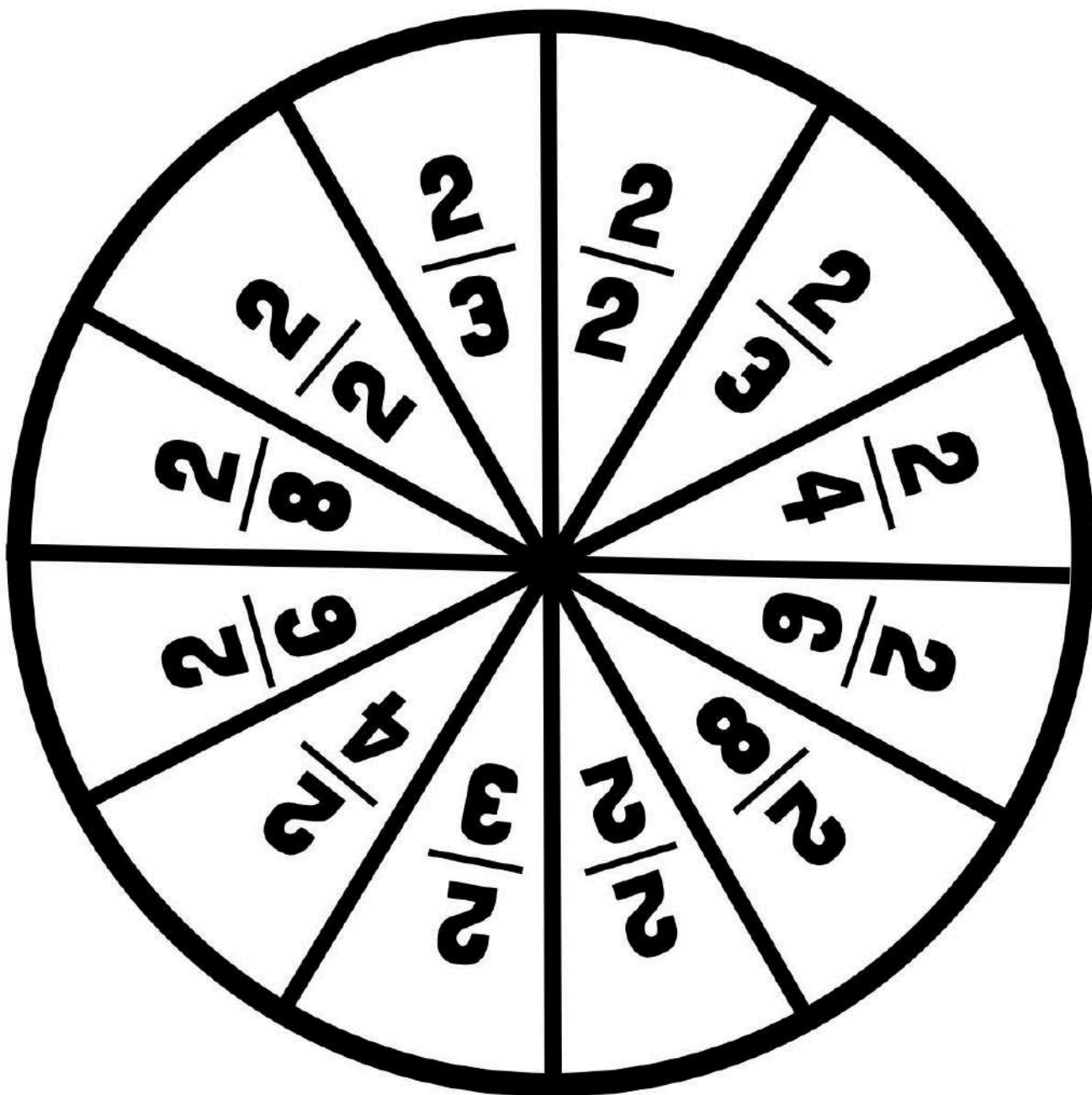

SPINNER

Use these cards for different games to compare, make equivalent fractions, add, subtraction, multiply and divide.

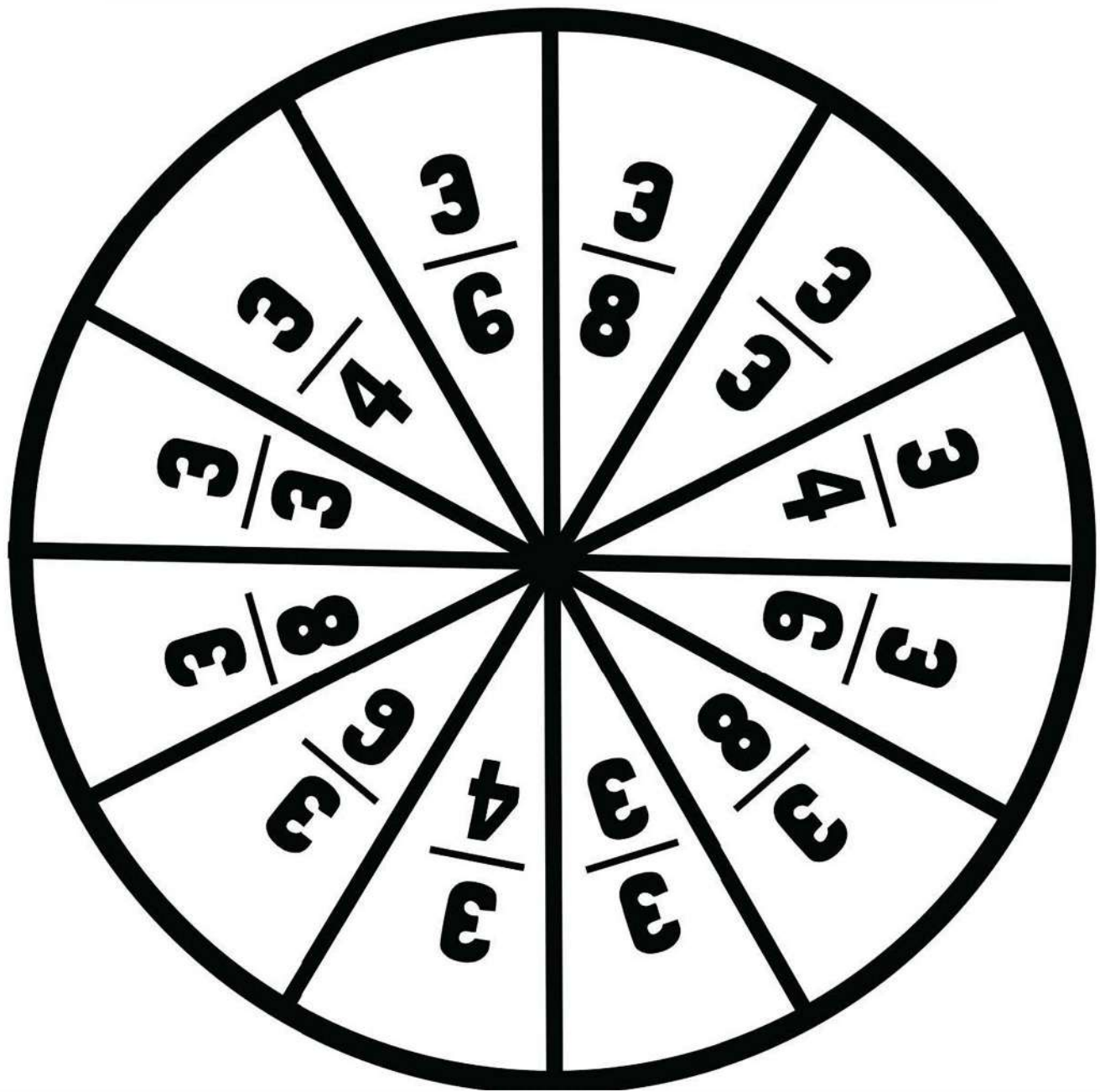

Use these cards for different games to compare, make equivalent fractions, add, subtraction, multiply and divide.

$$\frac{1}{2}$$

$$\frac{2}{2}$$

$$\frac{1}{4}$$

$$\frac{2}{4}$$

$$\frac{3}{4}$$

$$\frac{4}{4}$$

$$\frac{1}{3}$$

$$\frac{2}{3}$$

$$\frac{3}{3}$$

$$\frac{1}{6}$$

$$\frac{2}{6}$$

$$\frac{3}{6}$$

$$\frac{4}{6}$$

$$\frac{5}{6}$$

$$\frac{6}{6}$$

$$\frac{1}{8}$$

$$\frac{2}{8}$$

$$\frac{3}{8}$$

$$\frac{4}{8}$$

$$\frac{5}{8}$$

$$\frac{6}{8}$$

$$\frac{7}{8}$$

$$\frac{8}{8}$$

$$\frac{0}{2}$$

$$\frac{0}{2}$$

$$\frac{0}{3}$$

$$\frac{0}{1}$$

$$\frac{0}{5}$$

Use these cards for different games to compare, make equivalent fractions, add, subtraction, multiply and divide.

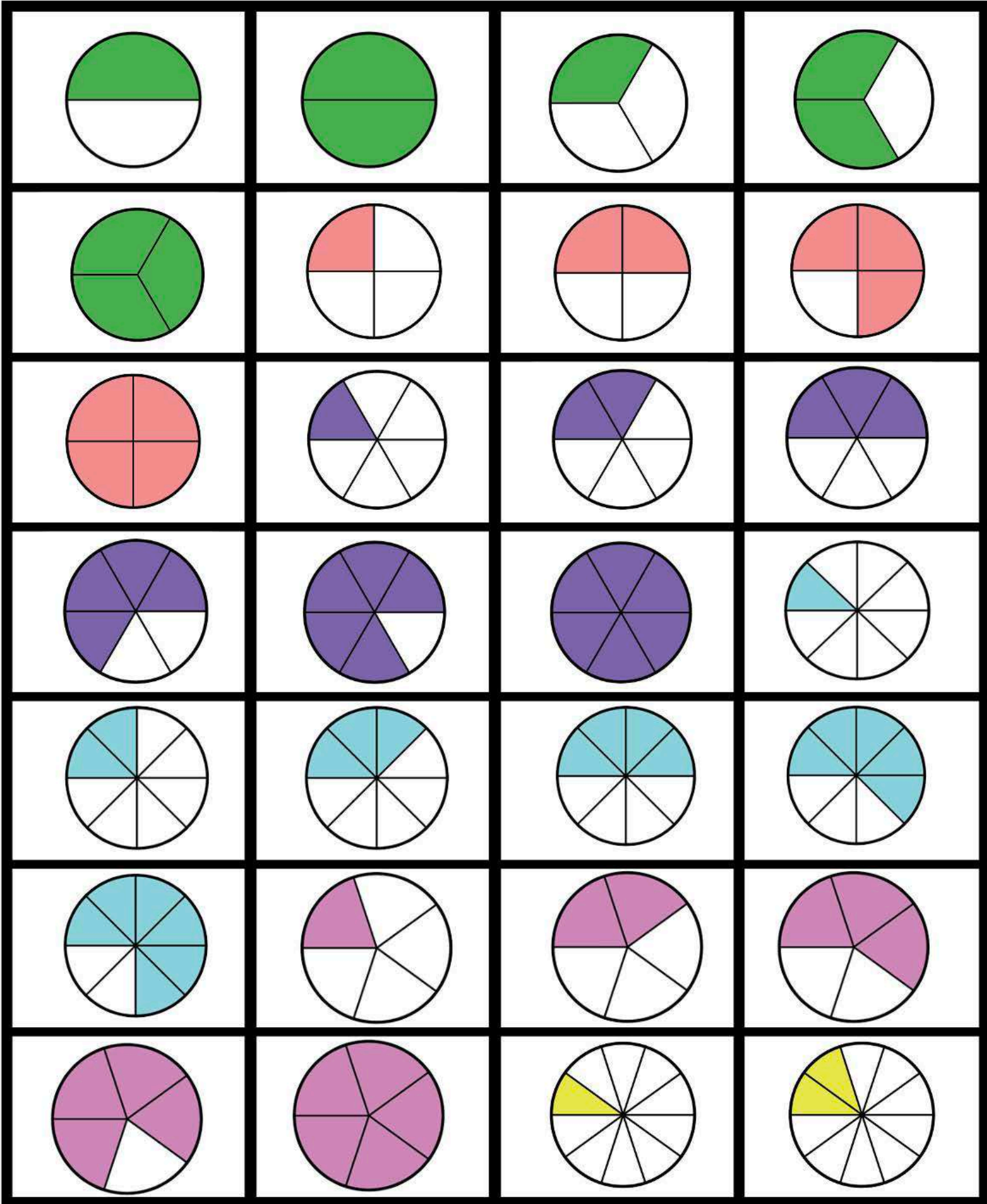

Use these cards for different games to compare, make equivalent fractions, add, subtraction, multiply and divide.

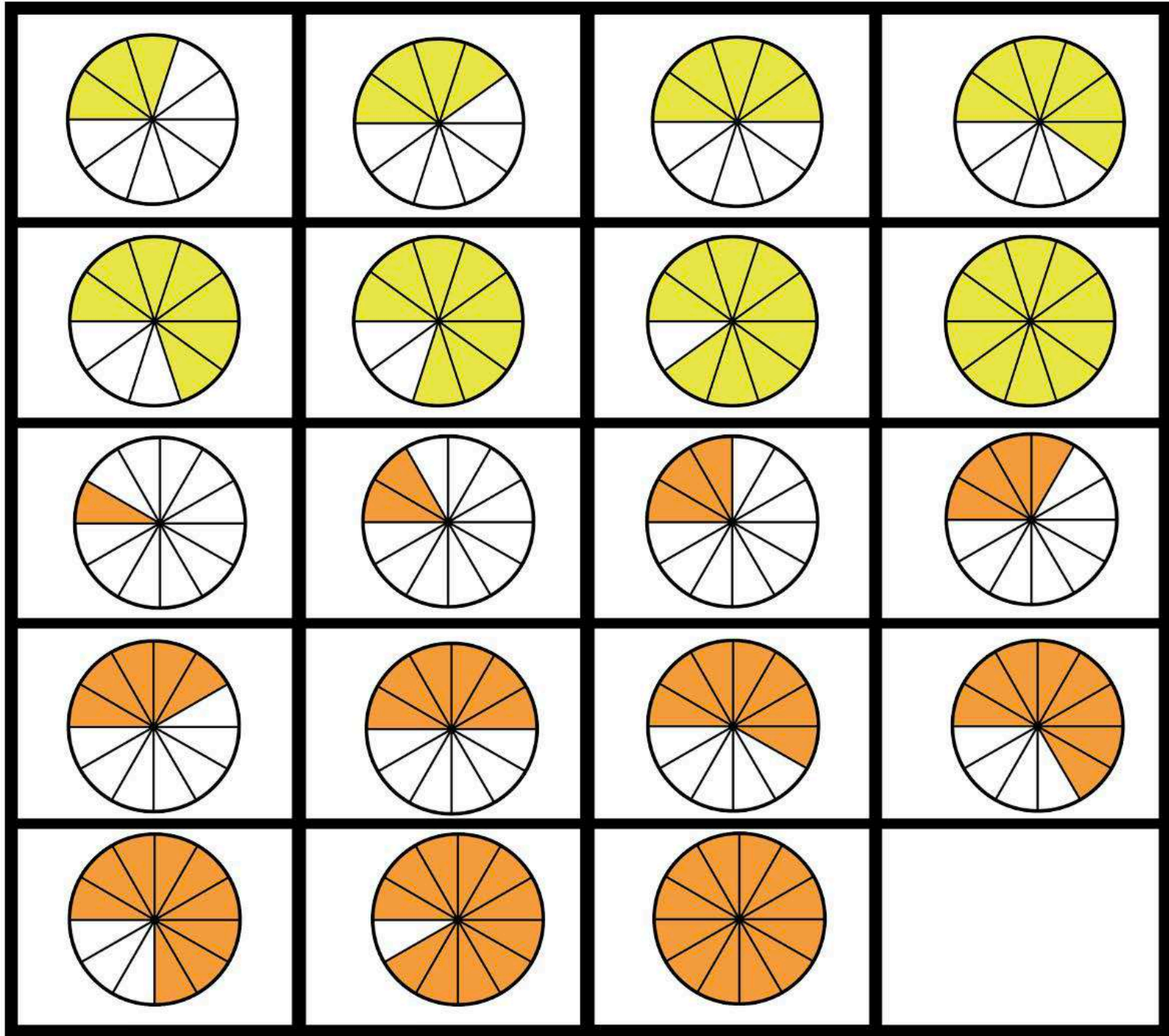

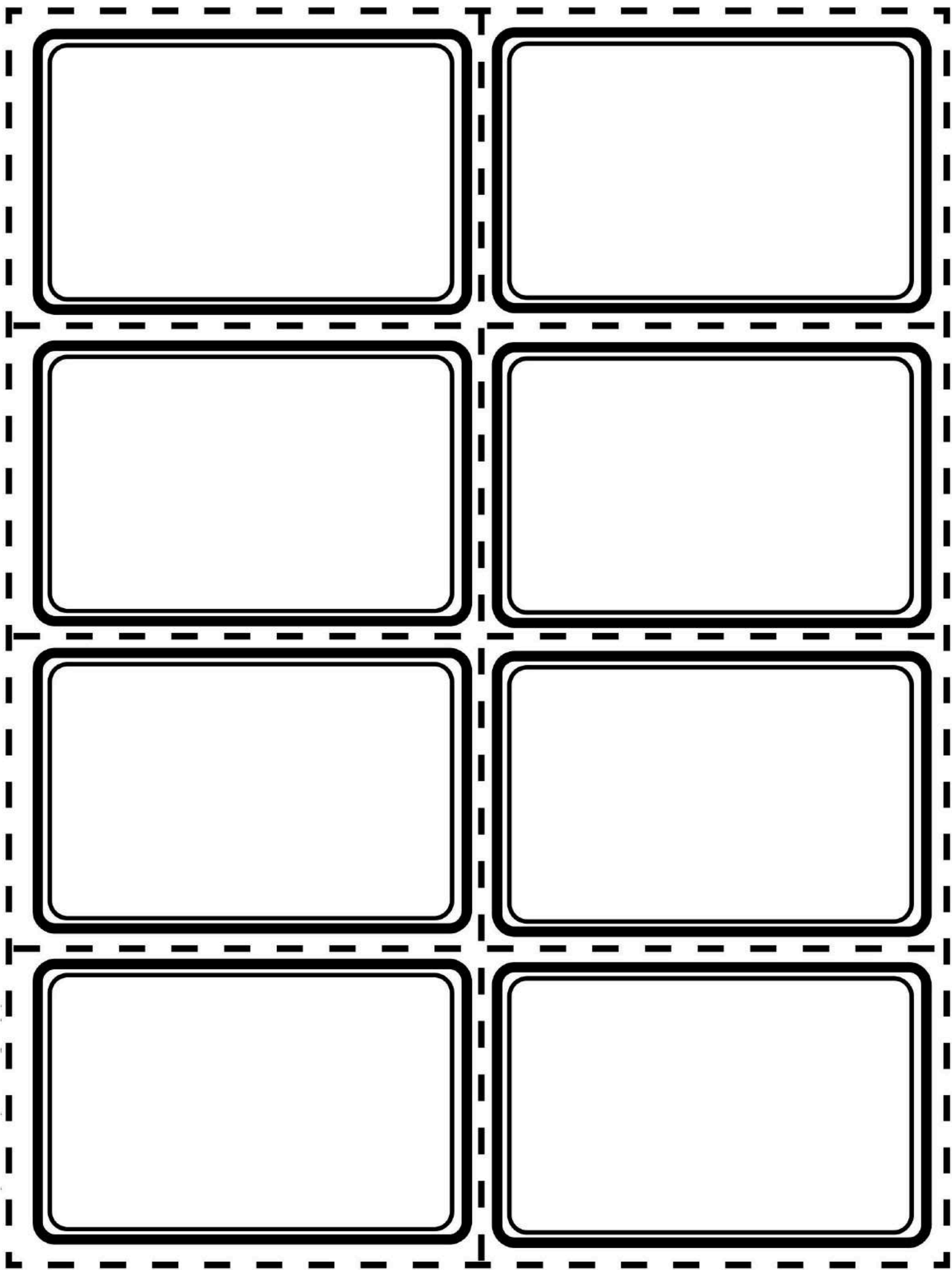



Math Fact Fluency Playground

See it, do it, learn it!

Math Fact Fluency Playground has one mission: Every student can learn and do math!

We work with teachers, schools, districts, regions and state educational agencies to help create a better math world. We believe that when teachers know more students soar! We believe that together we can change the world by creating research-based, engaging, student-friendly, classroom-tested math resources. Building on the research that says instruction is the linchpin and creative, evidence based resources are a powerful tool, we provide powerful pd and amazing resources to help you turn your math story around!

Contact us today

www.mathfactfluencyplayground.com
drnicki@mathfactfluencyplayground.com

OTHER BOOKS IN THE SERIES

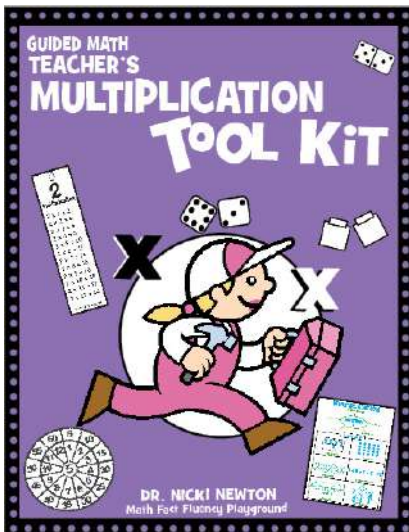
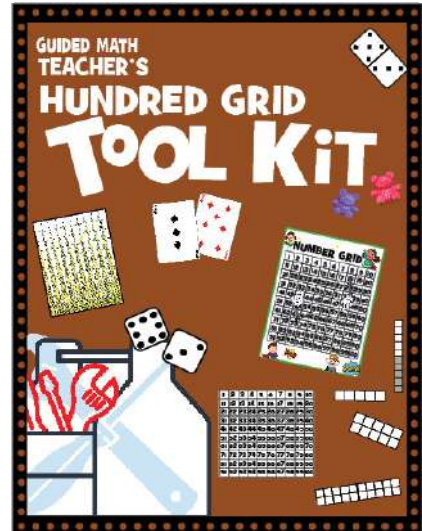
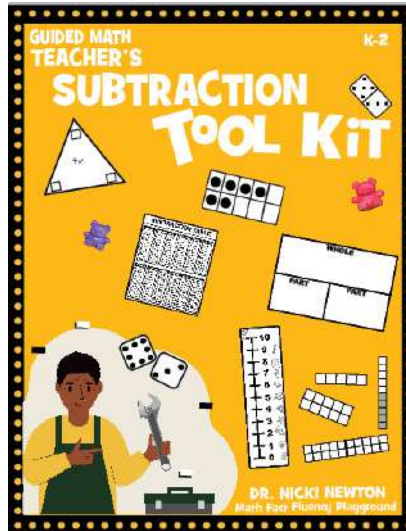
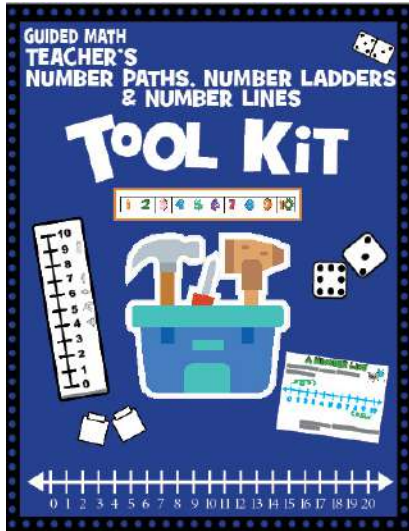

REFERENCES

Bruner, J. S. (1973). *Beyond the Information Given: Studies in the Psychology of Knowing*. New York: Norton.

Bruner, J. (1990). *Acts of Meaning*. Cambridge, MA: Harvard University Press.

Dewey, J. (1933). *How We Think. A restatement of the relation of reflective thinking to the educative process (Revised ed.)*, Boston: M.A.

Dewey, J. (1998). *Experience and Education: The 60th anniversary Edition*. Kappa Delta Pi. Nov. 1st.

National Council of Teachers of Mathematics (1991). *Professional standards for teaching mathematics*. Reston, VA.

Piaget, J. (1972). *To Understand Is To Invent*. New York: The Viking Press, Inc.

Robb, L. (2008). *Differentiating reading instruction: How to teach reading to meet the needs of each student*. New York. New York: Scholastic.

Serravallo, J. (2010) *Teaching Reading in Small Groups: Differentiated Instruction for Building Strategic, Independent Readers*. Nh: Heinemann.

Tomlinson , C.A. (1999). *How to differentiate instruction in mixed-ability classrooms*. Alexandria , VA : ASCD.

Tomlinson, C. A. (2001). *How to Differentiate Instruction in Mixed-Ability Classrooms*. Upper Saddle River, NJ: Pearson Education.

Vygotsky, L. S. (1978). *Mind in society: The development of higher psychological processes*. Massachusetts: Harvard University Press.

Tomlinson (2001), C.A. *So Each May Soar: The Principles and Practices of Learner-Centered Classrooms* ASCD. Alexandria, Virginia.

Fluency Doesn't Just Happen, It is a well-planned journey!



**BE SURE TO CHECK OUT OTHER
FLUENCY ACTIVITIES AT
WWW.MATHFACTFLUENCYPLAYGROUND.COM**



GUIDED MATH
TEACHER'S

FRACTION TOOL KIT

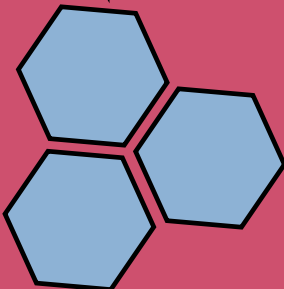
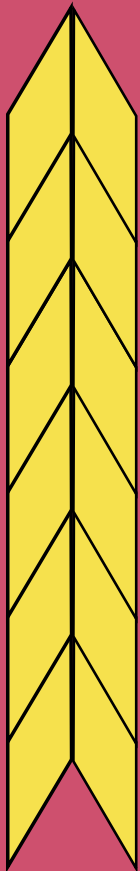
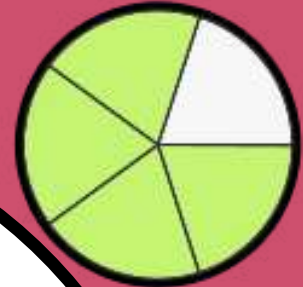
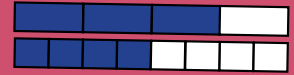
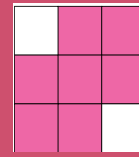
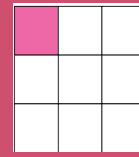

This Teacher's Fraction Resource Toolkit was created to help teach fractions. There are many different templates, activity sheets and blackline masters to differentiate instruction. Use these resources to scaffold access to grade level content for all your students!

The Guided Math Teacher's Fraction Toolkit is the essential resource for teachers to prepare and deliver hands-on, standards-based, visual lessons.